



SAFETY-RELIEF VALVE MODEL 1600

(SERIES 1646,1647,1648 & 16412)

***ASME**

UV CODED

NATIONAL BOARDED

* ASME UV CODED PER SEC. VIII DIV. I
AIR & GAS SERVICE.(PLASTIC SEAT ONLY)

AIR SERVICE MUST HAVE LIFT LEVER
SEE PAGE 60 FOR LIFTING DEVICES

R.F. FLANGE DIMENSIONS

*ORIFICE SIZE	INLET	OUTLET	A ±1/8	B ±1/8	C ±1/16
.800, * 1,000,* & 1,281 *	3-150	4-150	19-3/8	7-1/4	7-1/8
	3-300		19-3/8	7-1/4	7-1/8
	3-600		19-3/8	7-1/4	7-1/8
	3-900		19-3/8	7-1/4	7-1/8
4-150		19-3/8	7-1/4	7-1/8	
1,750	4-150	4-150	19-3/8	7-1/4	7-1/8

FOR R.T.J. DIMENSIONS, CONSULT FACTORY
SEE PAGE 23 & 24 FOR CAPACITY CHART

SERIES NO. §	ORIFICE SIZE	SEAT MATERIAL	SET PRESSURE RANGE
*1646	.800	PLASTIC ONLY	40 - 2,220
*1647	1,000	PLASTIC ONLY	40 - 2,220
*1648	1,281	PLASTIC ONLY	40 - 1,100
16412	1,750	PLASTIC ONLY	40 - 250

§ SEE PAGE 89 & 90 FOR PART NUMBERING SYSTEM.

SUGGESTED SEAT MATERIAL

SET PRESSURE	SEAT MATERIAL
40 - 2,000	TEFLON †
2,000 - 2,220	KEL-F †

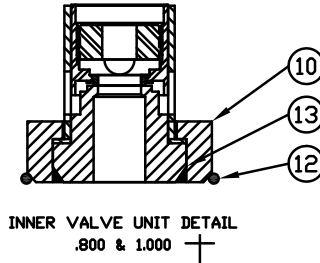
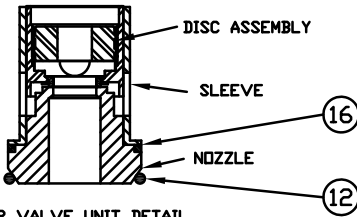
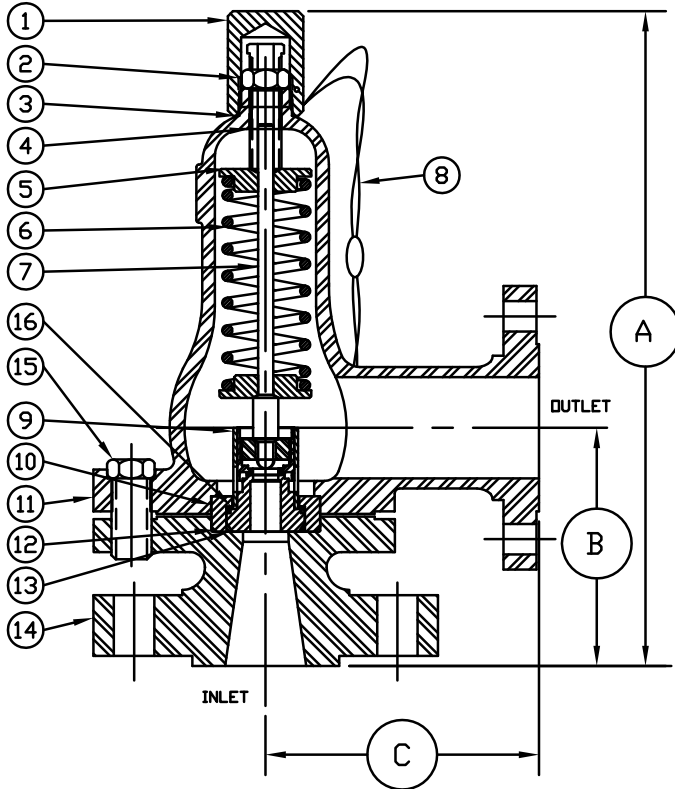

† TEMPERATURE RANGE
TEFLON : -450°F TO 500°F
KEL-F : -400°F TO 400°F

† OTHER SPRING MATERIALS
AVAILABLE UPON REQUEST.

WEIGHT IS APPROX. 95#
DEPENDING ON FANGE SIZE

† USE RETAINER RING FOR
THESE INNER VALVE UNITS
ONLY.

ITEM NO.	PART NAME	316 S/S MATERIAL CLASS	CARBON STEEL MATERIAL CLASS
1	HOOD	ASTM A479,TYPE 316	ASME SA29,TYPE 12L14
2	LOCKNUT	ASTM A479,TYPE 316	ASME SA29,TYPE 12L14
3	HOOD SEAL	TEFLON,BUNA-N,VITON	TEFLON,BUNA-N,VITON
4	PRESSURE SCREW	ASTM A479,TYPE 316	ASME SA29,TYPE 12L14
5	SPRING PLATES	ASTM A479,TYPE 316	ASTM A582,TYPE 303
6	SPRING	ASTM A313,TYPE 17/7	ASTM A313,TYPE 17/7
7	SPRING POST	ASTM A479,TYPE 316	ASTM A582,TYPE 303
8	SEAL & WIRE	LEAD SEAL:S/S WIRE	LEAD SEAL:S/S WIRE
9	INNER VALVE UNIT	303 S/S ; 316 S/S	303 S/S ; 316 S/S
10	RETAINER RING	ASTM A479,TYPE 316	ASTM A582,TYPE 303
11	BONNET	ASME A351,TYPE CF8M	ASME SA216,TYPE WCB
12	BODY SEAL	TEFLON,BUNA-N,VITON	TEFLON,BUNA-N,VITON
13	RETAINER SEAL	TEFLON,BUNA-N,VITON	TEFLON,BUNA-N,VITON
14	BODY	ASME A351,TYPE CF8M	ASME SA216,TYPE WCB
15	BOLTS (3 REQUIRED)	ASTM A479,TYPE 316	B7
16	B.P. SEAL	TEFLON,BUNA-N,VITON	TEFLON,BUNA-N,VITON