



# SAFETY-RELIEF VALVE

## MODEL 3600

(SERIES 360, 362, & 363)

FOR GAS & AIR SERVICE  
AT 10% OVERPRESSURE

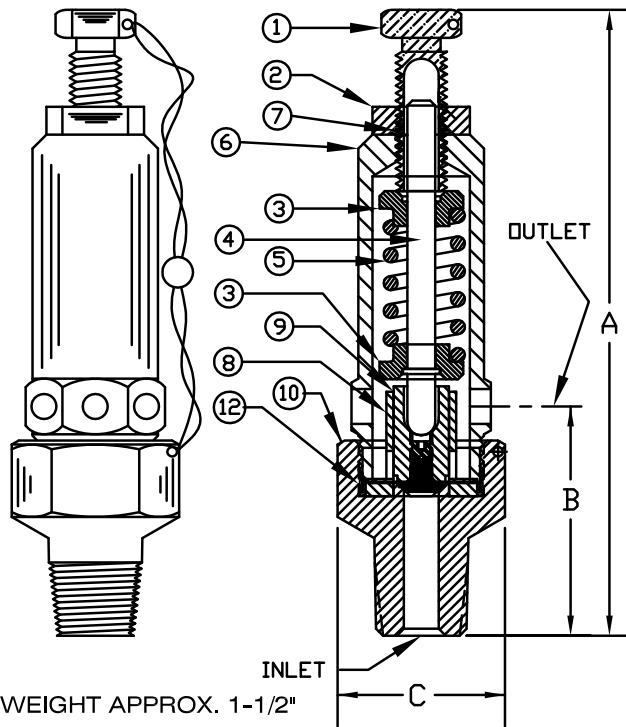

DIMENSIONS

A±1/8	B±1/8	C(HEX)	INLET CONNECTIONS
5-1/2	2-1/8	1-3/8	1/4,3/8,1/2,3/4 MNPT MS33649-8 1/2 FNPT
5-1/8	1-3/4	1-3/8	1/8,1/4,3/8 FNPT MS33649-4,6 1/4,3/8 AMINCO MS33656-4,6,8
5-1/2	1-3/4	1-1/2	9/16 AMINCO
6-1/2	3-1/8	1-3/8	1/2 SOCKET WELD

THREAD CONNECTIONS

ORIFICE SIZE	INLET	OUTLET
.156 & .250	1/4,3/8,1/2,3/4 MNPT	OPEN
	1/8,1/4,3/8,1/2 FNPT	1/8 FNPT
	MS33649-4,6,8	
	MS33656-4,6,8	
	1/4,3/8,9/16 HP AMINCO	
.312	1/2 SOCKET WELD	
	1/2,3/4 MNPT	OPEN
	1/2 FNPT	
	MS33649-8	
	MS33656-8	
	1/2 SOCKET WELD	

SEE PAGE 49 & 50 FOR CAPACITY CHARTS

SERIES NO. §	ORIFICE SIZE	SEAT MATERIAL	MAX. SET PRESS.	
			TG	MG
360	.156	PLASTIC ONLY	10,000	1,000
362	.250	PLASTIC ONLY	4,250	1,000
** 363	.312	PLASTIC ONLY	3,000	1,000

§ SEE PAGE 91 & 92 FOR PART NUMBERING SYSTEM.  
\*\* "O" RING DESIGN IS AVAILABLE UP TO 1,000 PSIG.

SUGGESTED SEAT MATERIAL

SET PRESSURE	SEAT MATERIAL
50 - 3,000	TEFLON †
3,000 - 5,000	KEL-F †
5,000 - 10,000	VESPEL †

† TEMPERATURE RANGE: TEFLON : -450°F TO 500°F  
KEL-F : -400°F TO 400°F  
VESPEL : -420°F TO 500°F

£ OTHER SPRING MATERIALS AVAILABLE UPON REQUEST.  
(HIGH PRESSURE SPRINGS ARE MADE OF 17-7 PH)

ITEM NO.	PART NAME	303 S/S MATERIAL CLASS	316 S/S MATERIAL CLASS	BRASS MATERIAL CLASS
1	PRESSURE SCREW	ASTM A582,TYPE 303	ASTM A479,TYPE 316	ASTM B16
2	LOCKNUT	ASTM A582,TYPE 303	ASTM A479,TYPE 316	ASTM B16
3	SPRING PLATES (2)	ASTM A582,TYPE 303	ASTM A479,TYPE 316	ASTM B16
4	SPRING POST	ASTM A582,TYPE 303	ASTM A479,TYPE 316	ASTM B16
£ 5	SPRING	ASTM A313,TYPE 316	ASTM A313,TYPE 316	ASTM A313,TYPE 316
6	BONNET	ASTM A313,TYPE 316	ASTM A313,TYPE 316	ASTM B16
7	LOCKNUT SEAL	TEFLON,BUNA-N,VITON	TEFLON,BUNA-N,VITON	TEFLON,BUNA-N,VITON
8	DISC GUIDE	ASTM A582,TYPE 303	ASTM A479,TYPE 316	ASTM B16
9	DISC ASSEMBLY	ASTM A582,TYPE 303	ASTM A479,TYPE 316	ASTM B16
10	BODY	ASTM A582,TYPE 303	ASTM A479,TYPE 316	ASTM B16
11	SEAL & WIRE	LEAD SEAL,S/S WIRE	LEAD SEAL,S/S WIRE	LEAD SEAL,S/S WIRE
12	BODY/BONNET SEAL	TEFLON,BUNA-N,VITON	TEFLON,BUNA-N,VITON	TEFLON,BUNA-N,VITON