



# SAFETY-RELIEF VALVE MODEL 1500

(SERIES 1521,1523,1524,1525 & 1529)

**\*ASME  
UV CODED  
NATIONAL BOARDED**

**\*ASME UV CODED PER SEC. VIII DIV. I  
AIR & GAS SERVICE.(PLASTIC SEATS ONLY)**

**AIR SERVICE MUST HAVE LIFT LEVER  
SEE PAGE 60 FOR LIFTING DEVICES**

### THREAD CONNECTIONS

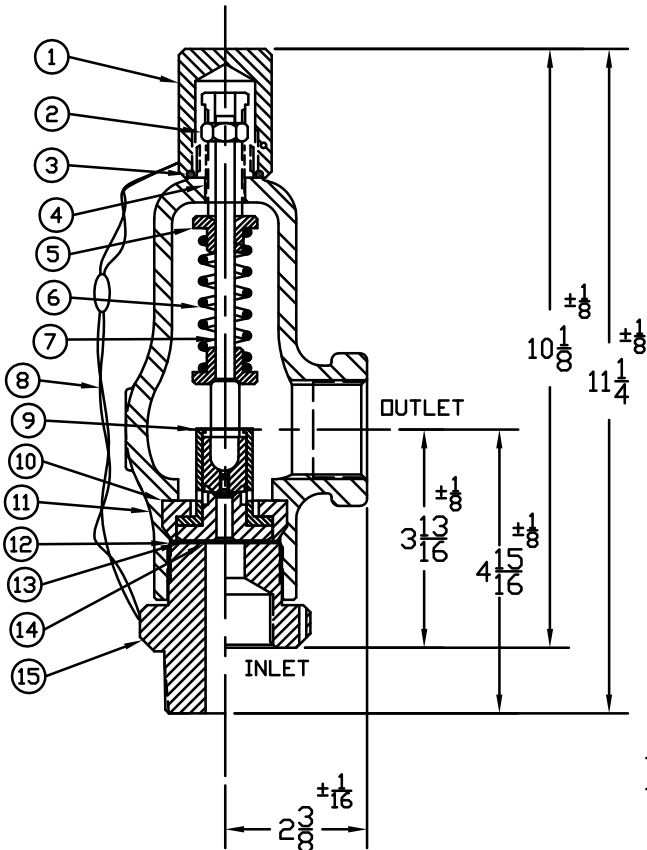

*ORIFICE SIZE	INLET	OUTLET
.187 & .250 *	1/2, 3/4, 1, 1 1/4, 1 1/2 MNPT	3/4, 1, 1 1/4, 1 1/2 FNPT
	1/2, 3/4, 1, 1 1/4, 1 1/2 FNPT	MS33649-12,16,20,24
	MS33649-8,10,12,16,20,24	GRAYLOC
	MS33656-8,10,12,16,24	
	9/16,3/4,1' AUTOCLAVE	
.375 *	3/4, 1, 1 1/4, 1 1/2 MNPT	1, 1 1/4, 1 1/2 FNPT
	3/4, 1, 1 1/4, 1 1/2 FNPT	MS33649-16,20,24
	MS33649-12,16,20,24	GRAYLOC
	MS33656-12,16,24	
	3/4,1' AUTOCLAVE	
.500 * & .625 *	1, 1 1/4, 1 1/2 MNPT	1, 1 1/2 FNPT
	1, 1 1/4, 1 1/2 FNPT	MS33649-16,24
	MS33649-16,20,24	GRAYLOC
	MS33656-16,24	
	1' AUTOCLAVE	

SEE PAGE 23 & 24 FOR CAPACITY CHART

SERIES NO. S	ORIFICE SIZE	SEAT MATERIAL	SET PRESSURE RANGE
* 1521	.250	PLASTIC ONLY	40 - 15,500
* 1523	.375	PLASTIC ONLY	40 - 8,000
* 1524	.500	PLASTIC ONLY	40 - 2,750
* 1525	.625	PLASTIC ONLY	40 - 1,500
1529	.187	PLASTIC ONLY	14,000 - 33,000

SEE PAGE 89 & 90 FOR PART NUMBERING SYSTEM.

### SUGGESTED SEAT MATERIAL

SET PRESSURE	SEAT MATERIAL
40 - 3,000	TEFLON †
3,000 - 5,000	KEL-F †
5,000 - 33,000	VESPEL †

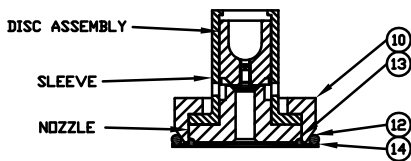

INNER VALVE UNIT WITH RETAINER RING (.125, .187, .250, & .375)

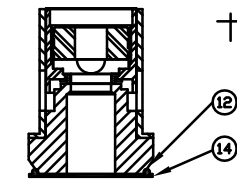

INNER VALVE UNIT (.500 & .625)

† TEMPERATURE RANGE  
TEFLON : -450°F TO 500°F  
KEL-F : -400°F TO 400°F  
VESPEL : -420°F TO 500°F

† OTHER SPRING MATERIALS AVAILABLE UPON REQUEST.

WEIGHT IS APPROX. 12#

† USE RETAINER & RETAINER SEAL FOR THESE INNER VALVE UNITS ONLY.

† \*\*\*IVU FOR .250 & .375 C/S OR 316 S/S CLASS HAS 303 S/S SLEEVE 316 S/S NOZZLE

ITEM NO.	PART NAME	316 S/S MATERIAL CLASS	CARBON STEEL MATERIAL CLASS
1	HOOD	ASTM A479,TYPE 316	ASME SA29,TYPE 12L14
2	LOCKNUT	ASTM A479,TYPE 316	ASME SA29,TYPE 12L14
3	HOOD SEAL	TEFLON,BUNA-N,VITON	TEFLON,BUNA-N,VITON
4	PRESSURE SCREW	ASTM A479,TYPE 316	ASME SA29,TYPE 12L14
5	SPRING PLATES	ASTM A479,TYPE 316	ASTM A582,TYPE 303
6	SPRING	ASTM A313,TYPE 17/7	ASTM A313,TYPE 17/7
7	SPRING POST	ASTM A479,TYPE 316	ASTM A582,TYPE 303
8	SEAL & WIRE	LEAD SEAL:S/S WIRE	LEAD SEAL:S/S WIRE
9	INNER VALVE UNIT***	ASTM A479,TYPE 316	ASTM A479,TYPE 316
10	RETAINER	ASTM A479,TYPE 316	ASTM A582,TYPE 303
11	BONNET	ASME SA351,TYPE CF8M	ASME SA216,TYPE WCB
12	BODY SEAL	TEFLON,BUNA-N,VITON	TEFLON,BUNA-N,VITON
13	RETAINER SEAL	TEFLON,BUNA-N,VITON	TEFLON,BUNA-N,VITON
14	GASKET	TEFLON	TEFLON
15	BODY	ASTM A479,TYPE 316	ASME SA29,TYPE 1018