



SAFETY-RELIEF VALVE

MODEL 3900

(SERIES 391, 392 & 393)

FOR AIR & GAS SERVICE
AT 10% OVERPRESSURE

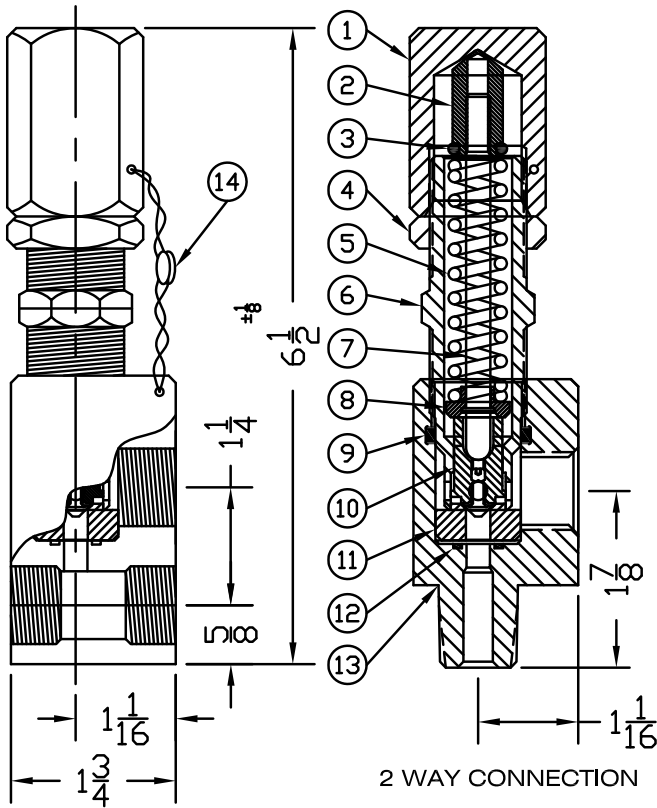

THREAD CONNECTIONS

ORIFICE SIZE	INLET	OUTLET
.187	1/4,3/8,1/2,3/4 MNPT	1/4,3/8,1/2 FNPT
	1/4,3/8,1/2 FNPT	MS33649-4,6,8
	MS33649-4,6,8	3/8 SOCKET WELD
	MS33656-6,8	
	1/4 AUTOCLAVE OR AMINCO	
.250	1/4,3/8,1/2,3/4 MNPT	1/4,3/8,1/2 FNPT
	1/4,3/8,1/2 FNPT	MS33649-4,6,8
	3/8,1/2 SOCKET WELD	3/8 SOCKET WELD
	MS33649-4,6,8	
	MS33656-6,8	
	9/16 AUTOCLAVE	
.312	3/8,1/2 MNPT	3/8,1/2 FNPT
	3/8,1/2 FNPT	MS33649-6,8
	3/8,1/2 SOCKET WELD	3/8 SOCKET WELD
	MS33649-6,8	
	MS33656-6,8	

SERIES NO. §	ORIFICE SIZE	SEAT MATERIAL	MAX. SET PRESSURE
391	.187	PLASTIC ONLY	6,750
392	.250	PLASTIC ONLY	4,400
393	.312	PLASTIC ONLY	3,600

§ SEE PAGE 91 & 92 FOR PART NUMBERING SYSTEM.

SUGGESTED SEAT MATERIAL

WEIGHT IS APPROX. 2-1/2#

¶ TEMPERATURE RANGE: TEFLON : -450°F TO 500°F
KEL-F : -400°F TO 400°F
VESPEL : -420°F TO 500°F

SET PRESSURE	SEAT MATERIAL
50 - 3,000	TEFLON ¶
3,000 - 5,000	KEL-F ¶
5,000 - 6,750	VESPEL ¶

ITEM NO.	PART NAME	303 S/S MATERIAL CLASS	316 S/S MATERIAL CLASS	CARBON STEEL MATERIAL CLASS
1	HOOD	ASTM A582,TYPE 303	ASTM A479,TYPE 316	ASME SA29,TYPE 12L14
2	SPRING PLUNGER	ASTM A582,TYPE 303	ASTM A479,TYPE 316	ASTM A582,TYPE 303
3	SPRING PLUNGER SEAL	TEFLON,BUNA-N,VITON	TEFLON,BUNA-N,VITON	TEFLON,BUNA-N,VITON
4	LOCKNUT	ASTM A582,TYPE 303	ASTM A479,TYPE 316	ASME SA29,TYPE 12L14
5	SPRING	ASTM A313,TYPE 316	ASTM A313,TYPE 316	ASTM A313,TYPE 316
6	BONNET	ASTM A582,TYPE 303	ASTM A479,TYPE 316	ASTM A582,TYPE 303
7	SPRING POST	ASTM A582,TYPE 303	ASTM A479,TYPE 316	ASTM A582,TYPE 303
8	SPRING PLATE	ASTM A582,TYPE 303	ASTM A479,TYPE 316	ASTM A582,TYPE 303
9	BODY SEAL	TEFLON,BUNA-N,VITON	TEFLON,BUNA-N,VITON	TEFLON,BUNA-N,VITON
10	DISC ASSEMBLY	ASTM A582,TYPE 303	ASTM A479,TYPE 316	ASTM A582,TYPE 303
11	NOZZLE	ASTM A582,TYPE 303	ASTM A479,TYPE 316	ASTM A582,TYPE 303
12	NOZZLE SEAL	TEFLON,BUNA-N,VITON	TEFLON,BUNA-N,VITON	TEFLON,BUNA-N,VITON
13	BODY	ASTM A582,TYPE 303	ASTM A479,TYPE 316	ASME SA29,TYPE 12L14
14	SEAL & WIRE	LEAD SEAL:S/S WIRE	LEAD SEAL:S/S WIRE	LEAD SEAL:S/S WIRE