

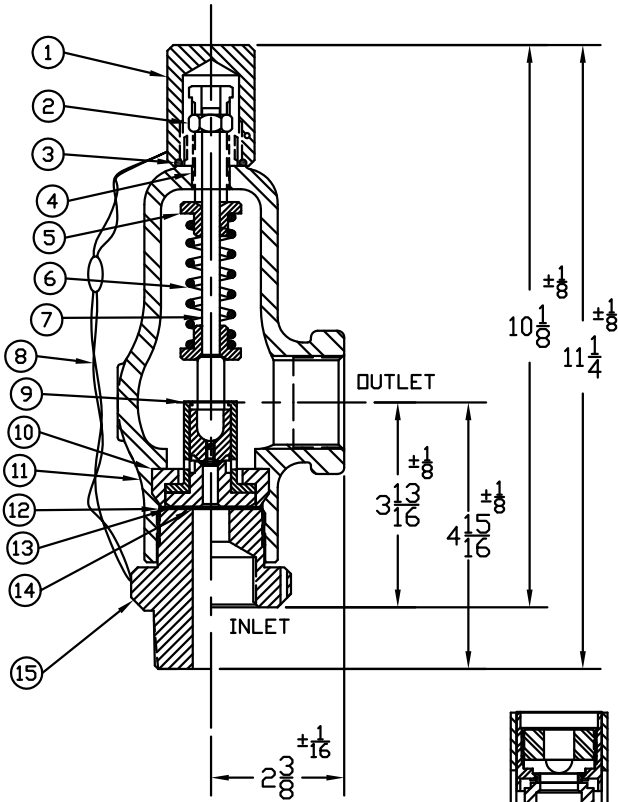

SAFETY-RELIEF VALVE MODEL 1500

(SERIES 1524,1525)

FOR AIR & GAS SERVICE
AT 10% OVERPRESSURE
METAL SEATS ONLY



THREAD CONNECTIONS

| ORIFICE SIZE | INLET | OUTLET |
|--------------|--------------------------|------------------|
| .500 & .625 | 1, 1 1/4, 1 1/2 MNPT | 1, 1 1/2 FNPT |
| | 1, 1 1/4, 1 1/2 FNPT | MS33649-16,20,24 |
| | MS33649-16,20,24 GRAYLOC | GRAYLOC |
| | MS33656-16,24 | |
| | 1" AUTOCLAVE | |

| SERIES NO. § | ORIFICE SIZE | SEAT MATERIAL | SET PRESSURE RANGE |
|--------------|--------------|---------------|--------------------|
| 1524 | .500 | METAL ONLY | 40 - 1,000 |
| 1525 | .625 | METAL ONLY | 40 - 1,000 |

§ SEE PAGE 89 & 90 FOR PART NUMBERING SYSTEM.

WEIGHT IS APPROX. 12#

***IVU FOR .250 & .375
C/S OR 316 S/S CLASS IS
303 S/S SLEEVE
316 S/S NOZZLE

† OTHER SPRING MATERIALS
AVAILABLE UPON REQUEST.

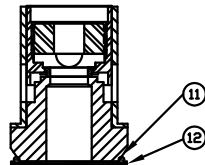

INNER VALVE UNIT
(.500 & .625)

| ITEM NO. | PART NAME | 316 S/S MATERIAL CLASS | CARBON STEEL MATERIAL CLASS |
|----------|---------------------|------------------------|-----------------------------|
| 1 | HOOD | ASTM A479,TYPE 316 | ASME SA29,TYPE 12L14 |
| 2 | LOCKNUT | ASTM A479,TYPE 316 | ASME SA29,TYPE 12L14 |
| 3 | HOOD SEAL | TEFLON,BUNA-N,VITON | TEFLON,BUNA-N,VITON |
| 4 | PRESSURE SCREW | ASTM A479,TYPE 316 | ASME SA29,TYPE 12L14 |
| 5 | SPRING PLATES | ASTM A479,TYPE 316 | ASTM A582,TYPE 303 |
| † 6 | SPRING | ASTM A313,TYPE 17/7 | ASTM A313,TYPE 17/7 |
| 7 | SPRING POST | ASTM A479,TYPE 316 | ASME SA29,TYPE 12L14 |
| 8 | SEAL & WIRE | LEAD SEAL:S/S WIRE | LEAD SEAL:S/S WIRE |
| 9 | INNER VALVE UNIT*** | ASTM A479,TYPE 316 | ASTM A479,TYPE 316 |
| 10 | BONNET | ASME SA351,TYPE CF8M | ASME SA216,TYPE WCB |
| 11 | BODY SEAL | TEFLON,BUNA-N,VITON | TEFLON,BUNA-N,VITON |
| 12 | GASKET | TEFLON | TEFLON |
| 13 | BODY | ASTM A479,TYPE 316 | ASME SA29,TYPE 1018 |