



SAFETY-RELIEF VALVE MODEL B4400

(SERIES B441,B442,B443,B445 & B446)

FOR AIR AND GAS SERVICE
AT 10% OVERPRESSURE
THREAD CONNECTIONS

SEE PAGE 60 FOR LIFTING DEVICES.

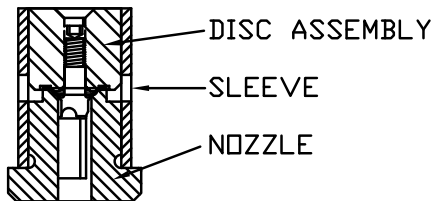
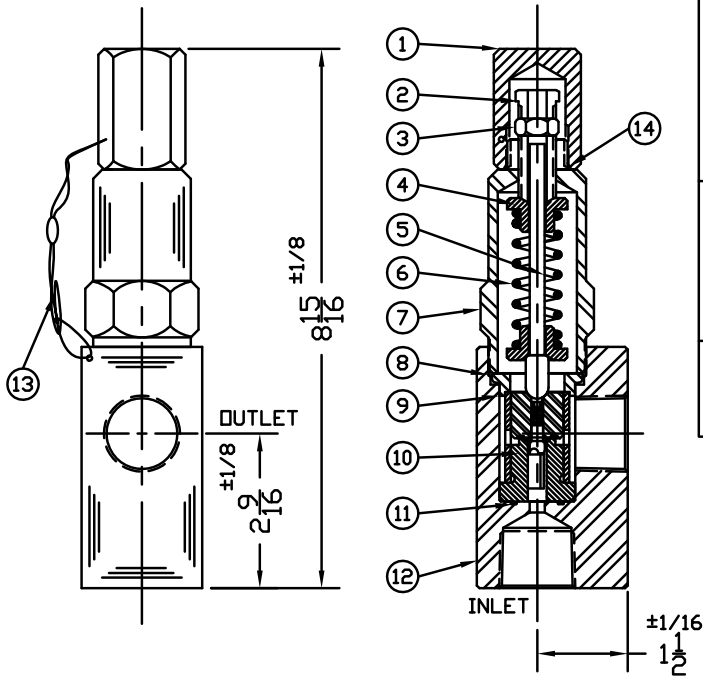

INNER VALVE UNIT DETAIL

ORIFICE SIZE	INLET	OUTLET
.187 & .250	1/4,3/8,1/2,3/4,1 FNPT	3/8,1/2,3/4,1 FNPT
	3/8,1/2,3/4,1 MNPT	MS33649-8,12,16
	1/4,9/16 AMINCO	MS16142-8
	9/16,3/4 AUTOCLAVE	
	MS33649-8,12,16 MS16142-8	
.312	3/8,1/2,3/4,1 FNPT	1/2,3/4,1 FNPT
	3/8,1/2,3/4,1 MNPT	MS33649-8,12,16
	9/16 AMINCO	
	9/16,3/4 AUTOCLAVE MS33649-8,12,16	
.437 & .500	3/4,1 FNPT	3/4,1 FNPT
	3/4,1 MNPT	MS33649-12,16
	MS33649-12,16	

SEE PAGE 53 & 54 FOR CAPACITY CHARTS.

SERIES NO. §	ORIFICE SIZE	SEAT MATERIAL	SET PRESSURE RANGE
B441	.187	PLASTIC ONLY	50 - 15,000
B442	.250	PLASTIC ONLY	50 - 13,200
B443	.312	PLASTIC ONLY	50 - 9,200
B445	.437	PLASTIC ONLY	50 - 4,000
B446	.500	PLASTIC ONLY	50 - 2,000

§ SEE PAGE 91 & 92 FOR PART NUMBERING SYSTEM.

SUGGESTED SEAT MATERIAL

SET PRESSURE	SEAT MATERIAL
50 - 3,000	TEFLON †
3,000 - 5,000	KEL-F †
5,000 - 15,000	VESPEL †

WEIGHT IS APPROX. 7#

† OTHER SPRING MATERIALS UPON REQUEST.

† TEMPERATURE RANGE: TEFLON : -450°F TO 500°F

KEL-F : -400°F TO 400°F

VESPEL : -420°F TO 500°F

ITEM NO.	PART NAME	303 S/S MATERIAL CLASS	316 S/S MATERIAL CLASS
1	HOOD	ASTM A582,TYPE 303	ASTM A479,TYPE 316
2	PRESSURE SCREW	ASTM A582,TYPE 303	ASTM A479,TYPE 316
3	LOCKNUT	ASTM A582,TYPE 303	ASTM A479,TYPE 316
4	SPRING PLATES (2)	ASTM A582,TYPE 303	ASTM A479,TYPE 316
5	SPRING POST	ASTM A582,TYPE 303	ASTM A479,TYPE 316
6	SPRING	ASTM A313,TYPE 316	ASTM A313,TYPE 316
7	BONNET	ASTM A582,TYPE 303	ASTM A479,TYPE 316
8	BODY SEAL	TEFLON,BUNA-N,VITON	TEFLON,BUNA-N,VITON
9	RETAINER RING	ASTM A582,TYPE 303	ASTM A479,TYPE 316
10	INNER VALVE UNIT	ASTM A582,TYPE 303	ASTM A479,TYPE 316
11	NOZZLE SEAL	TEFLON,BUNA-N,VITON	TEFLON,BUNA-N,VITON
12	BODY	ASTM A582,TYPE 303	ASTM A479,TYPE 316
13	SEAL & WIRE	LEAD SEAL/S/S WIRE	LEAD SEAL/S/S WIRE
14	HOOD SEAL	TEFLON,BUNA-N,VITON	TEFLON,BUNA-N,VITON