

F
M

SAFETY-RELIEF VALVE

MODEL 4700 - 4900

GENERAL DESCRIPTION: THESE PRECISION MADE SAFETY RELIEF VALVES FEATURE REPLACEABLE INNER VALVE UNITS OF STAINLESS STEEL AND EXCEPTIONALLY HEAVY CAST METAL BODIES ON THE 4700 MODEL. PERFORMANCE IS BUBBLE-TIGHT AFTER REPEATED OPERATIONS. MODEL 4700 AND 4900 VALVES ARE HIGHLY SUITABLE TO OIL FIELD AND PROCESSING USE.

APPLICATIONS INCLUDE:

- GAS AND AIR SYSTEMS
- OIL AND GAS SEPERATORS
- GAS DEHYDRATION SYSTEMS
- GAS BOOSTER SYSTEMS
- NON-COOKING REFINERY SERVICE
- PIPELINE INJECTION PUMPS
- SALT WATER DISPOSAL PUMPS
- HYDRAULIC PRESSURE SYSTEMS
- RECIPROCATING PUMPS
- CHEMICAL PROCESSING
- NAVAL APPLICATIONS

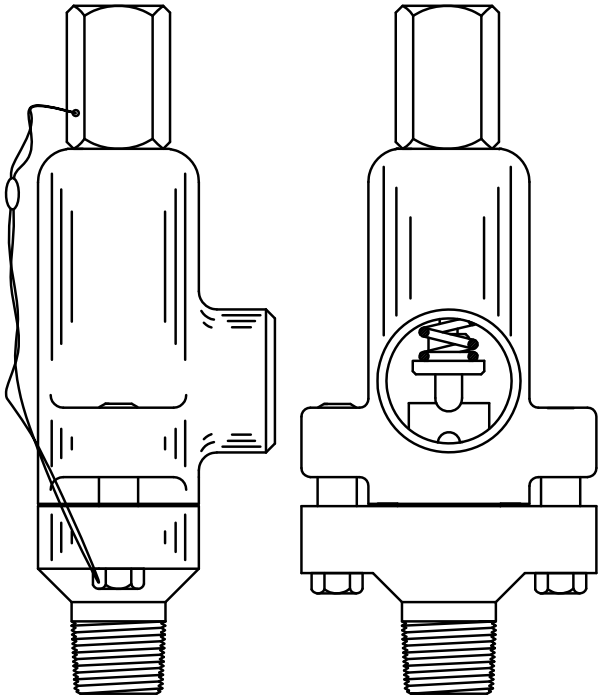

MODEL 4700

REPLACEABLE INNER VALVE UNITS: CONSISTS OF A STAINLESS STEEL NOZZLE AND STAINLESS STEEL DISC WHICH ARE GROUND AND TESTED AS A UNIT.

STRESS-FREE NOZZLE: THE STAINLESS STEEL NOZZLE IS FREE OF TORQUE STRESS AND DISTORTION AROUND THE SEAT AREA SINCE IT IS NOT SCREWED INTO THE MAIN BODY.

BODY AND BONNET: ARE AVAILABLE IN CARBON STEEL, STAINLESS STEEL AND BRONZE.

SPRING: IS AVAILABLE IN VARIOUS STEEL ALLOYS.

LIFT LEVERS: CAN BE FURNISHED.

FACTORY TESTED: EACH MODEL 4700 & 4900 FLUID MECHANICS SAFETY RELIEF VALVE IS FACTORY TESTED AND FULLY WARRANTED FOR ONE YEAR.

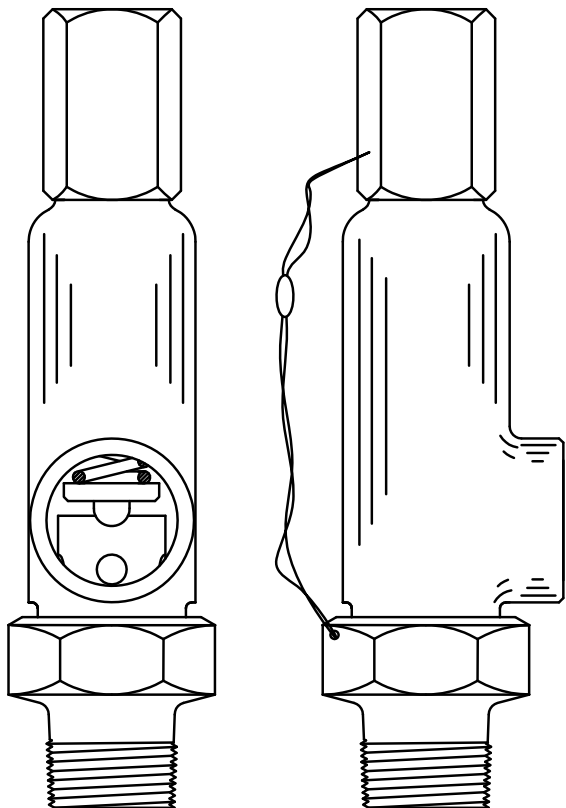

MODEL 4900