



SAFETY-RELIEF VALVE

MODEL 4800

(SERIES 484 & 486)

FOR AIR AND GAS SERVICE
AT 10% OVERPRESSURE

R.F. FLANGE DIMENSIONS

SEE PAGE 60 FOR LIFTING DEVICES

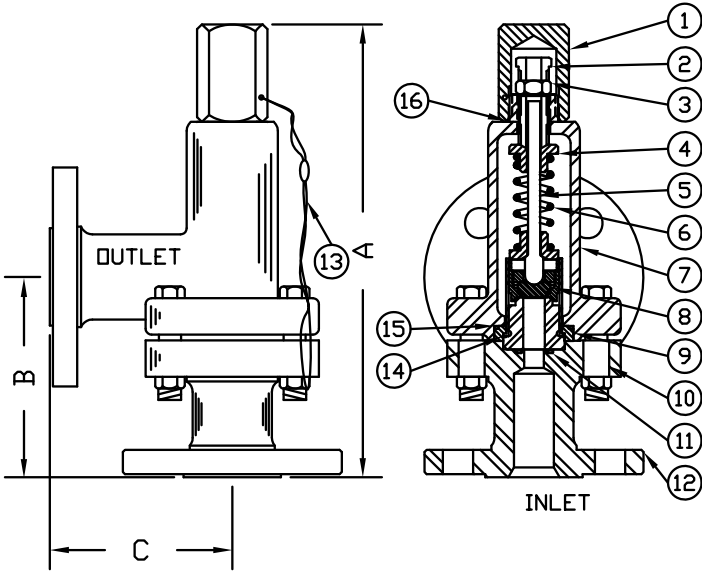

ORIFICE SIZE	INLET & OUTLET	A ±1/8	B ±1/8	C ±1/16
.375	1/2-150 x 3/4-300	9	4-3/8	3-11/16
	3/4-150 x 1-150	9	4-3/8	3-11/16
	3/4-300 x 1-150	9	4-3/8	3-11/16
	3/4-600 x 1-150	9	4-3/8	3-11/16
	3/4-900 x 1-300	9	4-3/8	3-11/16
	1-150 x 1½-150	9-9/16	4-7/16	4-3/16
	1-300 x 1½-150	9-9/16	4-7/16	4-3/16
	1-600 x 1½-300	9-9/16	4-7/16	4-3/16
.500	1-900 x 1½-300	9-9/16	4-7/16	4-3/16
	1-150 x 1½-150	9-9/16	4-7/16	4-3/16
	1-300 x 1½-150	9-9/16	4-7/16	4-3/16
	1-600 x 1½-300	9-9/16	4-7/16	4-3/16
	1-900 x 1½-300	9-9/16	4-7/16	4-3/16
	1½-150 x 2-150	9-9/16	4-7/16	4-3/16
	1½-300 x 2-150	9-9/16	4-7/16	4-3/16
	1½-600 x 2-300	9-9/16	4-7/16	4-3/16
1½-900 x 2-300	9-9/16	4-7/16	4-3/16	

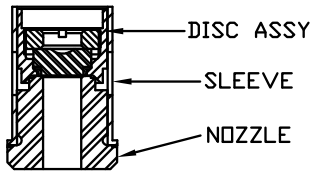

INNER VALVE UNIT DETAIL
PLASTIC SEAT

SERIES NO. §	ORIFICE SIZE	SEAT MATERIAL	SET PRESSURE RANGE
484	.375	PLASTIC ONLY	50 - 5,000
486	.500	PLASTIC ONLY	50 - 2,000

SUGGESTED SEAT MATERIAL

SET PRESSURE	SEAT MATERIAL
50 - 3,000	TEFLON †
3,000 - 5,000	KEL-F †
3,000 - 5,000	VESPEL †

ITEM NO.	PART NAME	316 S/S MATERIAL CLASS	CARBON STEEL MATERIAL CLASS
1	HOOD	ASTM A479,TYPE 316	ASME SA29,TYPE 12L14
2	PRESSURE SCREW	ASTM A479,TYPE 316	ASME SA29,TYPE 12L14
3	LOCKNUT	ASTM A479,TYPE 316	ASME SA29,TYPE 12L14
4	SPRING PLATES (2)	ASTM A479,TYPE 316	ASTM A582,TYPE 303
5	SPRING POST	ASTM A479,TYPE 316	ASTM A582,TYPE 303
6	SPRING	ASTM A313,TYPE 316	ASTM A313,TYPE 316
7	BONNET	ASME A351,TYPE CF8M	ASME SA216,TYPE WCB
8	INNER VALVE UNIT	ASTM A479,TYPE 316	ASTM A582,TYPE 303
9	RETAINER RING	ASTM A479,TYPE 316	ASTM A582,TYPE 303
10	BOLTS (4)	ASTM A479,TYPE 316	ASME SA29,TYPE 12L14
11	NOZZLE SEAL	TEFLON,BUNA-N,VITON	TEFLON,BUNA-N,VITON
12	BODY	ASME A351,TYPE CF8M	ASME SA216,TYPE WCB
13	SEAL & WIRE	LEAD SEAL,S/S WIRE	LEAD SEAL,COPPER WIRE
14**	BACK PRESSURE SEAL	TEFLON OR METAL	TEFLON OR METAL
15**	RETAINER SEAL	TEFLON OR METAL	TEFLON OR METAL
16	HOOD SEAL	TEFLON,BUNA-N,VITON	TEFLON,BUNA-N,VITON

† TEMPERATURE RANGE
TEFLON : -450°F TO 500°F
KEL-F : -400°F TO 400°F
VESPEL : -420°F TO 500°F

† OTHER SPRING MATERIALS AVAILABLE UPON REQUEST.

WEIGHT IS APPROX. 15#

**AVAILABLE UPON REQUEST.

§ SEE PAGE 91 & 92 FOR PART NUMBERING SYSTEM.

SEE PAGE 55 & 56 FOR CAPACITY CHARTS.