



SAFETY-RELIEF VALVE

MODEL 1500

(SERIES 1513 & 1519)

FOR LIQUID SERVICE
AT 10% OVERPRESSURE

**THESE DIMENSIONS ARE GOOD FOR
1" FNPT & MS33649-16 ALSO.

THREAD CONNECTIONS

ORIFICE SIZE	INLET	OUTLET
.187	1/4,3/8,1/2,3/4, 1" FNPT	1/2,3/4, 1" FNPT
	1/4,3/8,1/2,3/4, 1" MNPT	MS33649-4,6,8,12,16
	MS33649-4,6,8,10,12,16	
	MS33656-8,10,12,16	
	1/4,9/16,1" M.P. AUTOCLAVE	
	1/4,9/16,1" H.P. AMINCO	
.375	GRAYLOC	GRAYLOC
	3/4, 1" FNPT	1" FNPT
	3/4, 1" MNPT	MS33649-16
	MS33649-12,16 GRAYLOC	MS16142-16, 1" FLPT
	MS33656-12,16 3/4,1" AUTOCLAVE	GRAYLOC

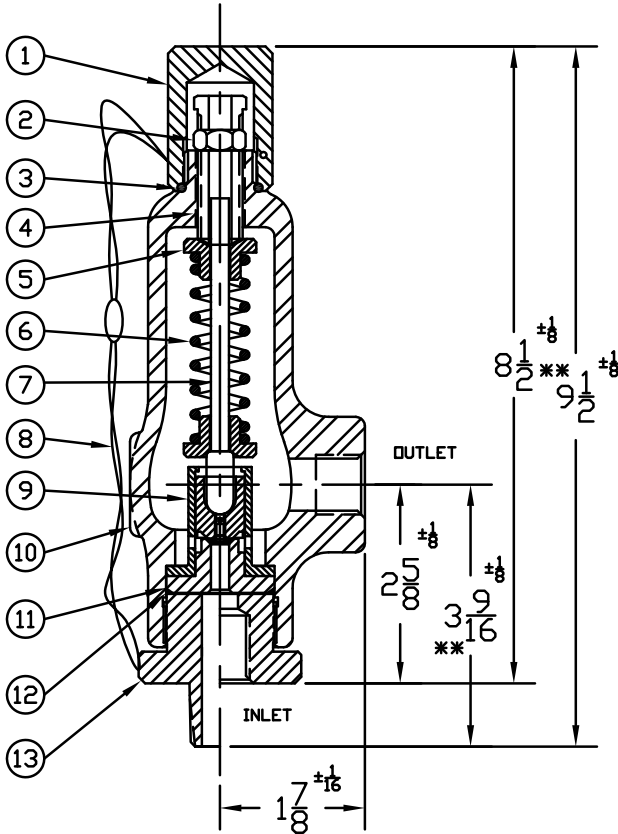

SERIES NO. §	ORIFICE SIZE	SEAT MATERIAL	SET PRESSURE RANGE
1519	.187	PLASTIC ONLY	40 - 15,000
1513	.375	PLASTIC ONLY	40 - 3,500

SUGGESTED SEAT MATERIAL

SET PRESSURE	SEAT MATERIAL
40 - 3,000	TEFLON †
3,000 - 5,000	KEL-F †
5,000 - 15,000	VESPEL †

§ SEE PAGE 89 & 90 FOR PART NUMBERING SYSTEM.

SEE PAGE 72 & 73 FOR CAPACITY CHART

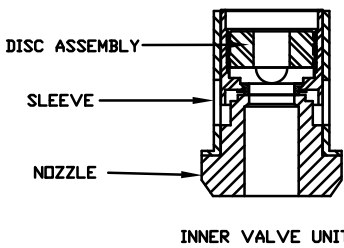

† OTHER SPRING MATERIALS
AVAILABLE UPON REQUEST.

WEIGHT IS APPROX. 7#

† TEMPERATURE RANGE
TEFLON : -450°F TO 500°F
KEL-F : -400°F TO 400°F

***IVU FOR .375
C/S OR 316 S/S CLASS HAS
303 S/S SLEEVE
316 S/S NOZZLE

ITEM NO.	PART NAME	316 S/S MATERIAL CLASS	CARBON STEEL MATERIAL CLASS
1	HOOD	ASTM A479,TYPE 316	ASME SA29,TYPE 12L14
2	LOCKNUT	ASTM A479,TYPE 316	ASME SA29,TYPE 12L14
3	HOOD SEAL	TEFLON,BUNA-N,VITON	TEFLON,BUNA-N,VITON
4	PRESSURE SCREW	ASTM A479,TYPE 316	ASME SA29,TYPE 12L14
5	SPRING PLATES	ASTM A479,TYPE 316	ASTM A582,TYPE 303
6	SPRING	ASTM A313,TYPE 17/7	ASTM A313,TYPE 17/7
7	SPRING POST	ASTM A479,TYPE 316	ASTM A582,TYPE 303
8	SEAL & WIRE	LEAD SEAL,S/S WIRE	LEAD SEAL,S/S WIRE
9	INNER VALVE UNIT***	ASTM A479,TYPE 316	ASTM A479,TYPE 316
10	BONNET	ASME SA351,TYPE CF8M	ASME SA216,TYPE WCB
11	BODY SEAL	TEFLON,BUNA-N,VITON	TEFLON,BUNA-N,VITON
12	GASKET	TEFLON	TEFLON
13	BODY	ASME SA351,TYPE CF8M	ASME SA29,TYPE 1018