



# SAFETY-RELIEF VALVE

## MODEL 1500

(SERIES 1546 & 1548)

FOR LIQUID SERVICE  
AT 10% OVERPRESSURE

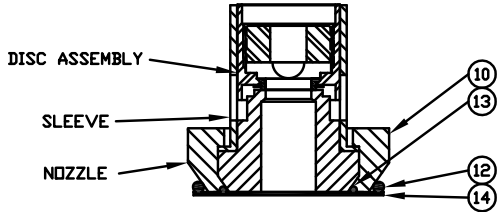
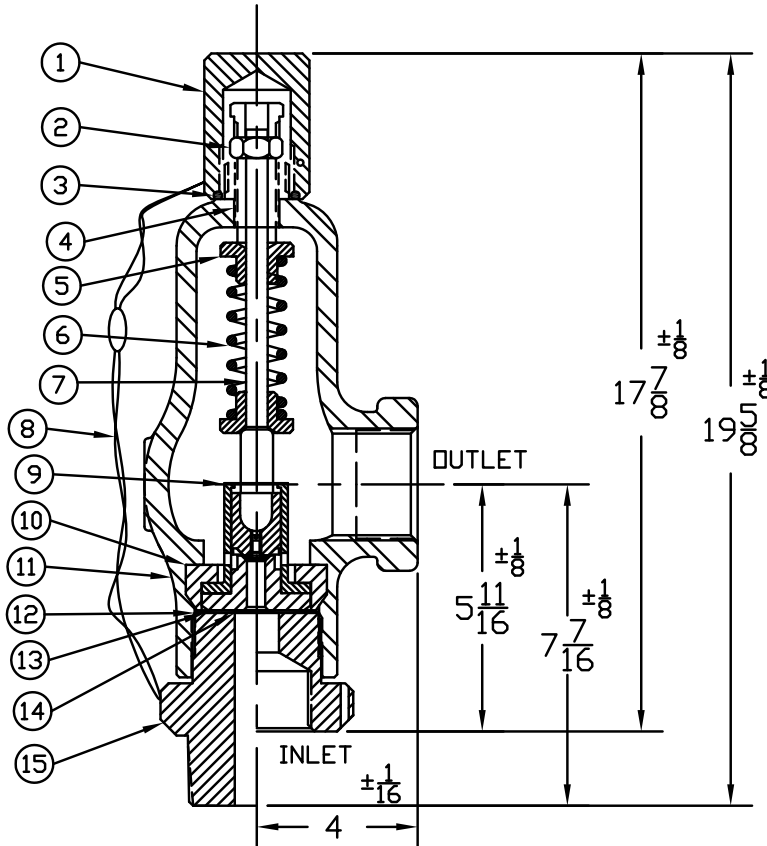

INNER VALVE UNIT  
WITH RETAINER RING  
(.800 & 1.000)

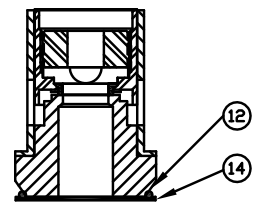

INNER VALVE UNIT  
(1.281)

### THREAD CONNECTIONS

ORIFICE SIZE	INLET	OUTLET
.800 & 1.281	2, 2½, 3" FNPT	2½, 3" FNPT
	2, 2½, 3" MNPT	
	MS33656-24,32	

§ SEE PAGE 89 & 90 FOR PART NUMBERING SYSTEM.

SERIES NO. §	ORIFICE SIZE	SEAT MATERIAL	SET PRESSURE RANGE
1546	.800	PLASTIC ONLY	40 - 3,500
1548	1.281	PLASTIC ONLY	40 - 1,100

### SUGGESTED SEAT MATERIAL

SET PRESSURE	SEAT MATERIAL
40 - 3,000	TEFLON †
3,000 - 3,500	KEL-F †

† OTHER SPRING MATERIALS  
AVAILABLE UPON REQUEST.

† USE RETAINER & RETAINER  
SEAL FOR THESE INNER  
VALVE UNITS ONLY.

† TEMPERATURE RANGE  
TEFLON : -450°F TO 500°F  
KEL-F : -400°F TO 400°F

WEIGHT IS APPROX. 45#

ITEM NO.	PART NAME	316 S/S MATERIAL CLASS	BRONZE MATERIAL CLASS	CARBON STEEL MATERIAL CLASS
1	HOOD	ASTM A479,TYPE 316	ASTM B16	ASME SA29,TYPE 12L14
2	LOCKNUT	ASTM A479,TYPE 316	ASTM A582,TYPE 303	ASME SA29,TYPE 12L14
3	HOOD SEAL	TEFLON,BUNA-N,VITON	TEFLON,BUNA-N,VITON	TEFLON,BUNA-N,VITON
4	PRESSURE SCREW	ASTM A479,TYPE 316	ASTM A582,TYPE 303	ASME SA29,TYPE 12L14
5	SPRING PLATES	ASTM A479,TYPE 316	ASTM A582,TYPE 303	ASTM A582,TYPE 303
6	SPRING	ASTM A313,TYPE 17/7	ASTM A313,TYPE 17/7	ASTM A313,TYPE 17/7
7	SPRING POST	ASTM A479,TYPE 316	ASTM A582,TYPE 303	ASTM A582,TYPE 303
8	SEAL & WIRE	LEAD SEAL:S/S WIRE	LEAD SEAL:S/S WIRE	LEAD SEAL:S/S WIRE
9	INNER VALVE UNIT	ASTM A479,TYPE 316	ASTM A479,TYPE 316	ASTM A479,TYPE 316
10	RETAINER	ASTM A479,TYPE 316	ASTM A582,TYPE 303	ASTM A582,TYPE 303
11	BONNET	ASME SA351,TYPE CF8M	ASTM B584,ALLOY 875	ASME SA216,TYPE WCB
12	BODY SEAL	TEFLON,BUNA-N,VITON	TEFLON,BUNA-N,VITON	TEFLON,BUNA-N,VITON
13	RETAINER SEAL	TEFLON,BUNA-N,VITON	TEFLON,BUNA-N,VITON	TEFLON,BUNA-N,VITON
14	GASKET	TEFLON	TEFLON	TEFLON
15	BODY	ASTM A479,TYPE 316	ASTM B16	ASME SA29,TYPE 1018