



SAFETY-RELIEF VALVE

MODEL 1600

SERIES 1613

FOR LIQUID SERVICE
AT 10% OVERPRESSURE

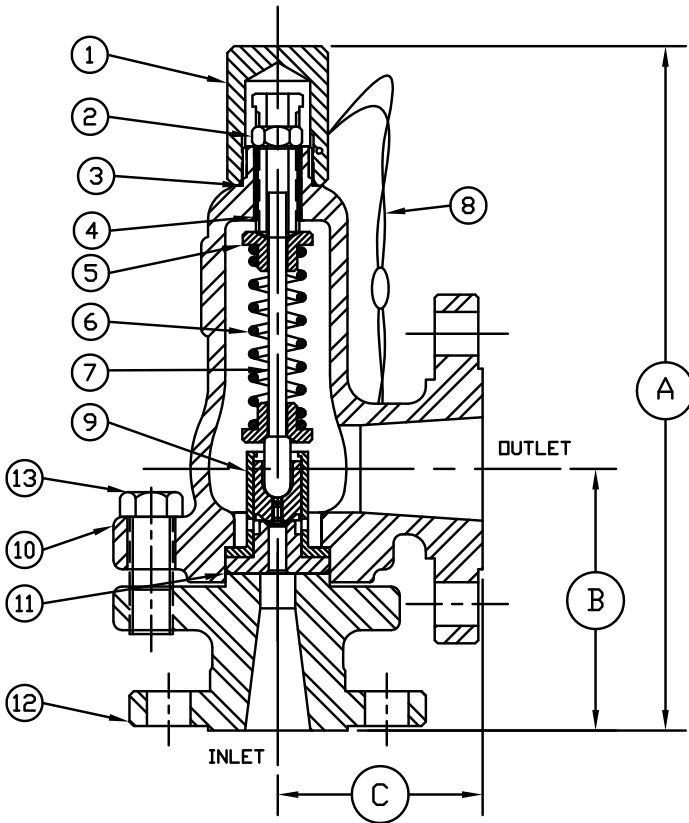

R.F. FLANGE DIMENSIONS

ORIFICE SIZE	INLET & OUTLET	A ±1/8	B ±1/8	C ±1/16
.375	1-150 x 1½-150	9-5/8	3-5/8	2-15/16
	1-300 x 1½-150	9-5/8	3-5/8	2-15/16
	1-600 x 1½-150	9-7/8	3-7/8	2-15/16
	1-900 x 1½-300	10-13/16	4-7/8	3-5/8
	1-1500 x 1½-300	10-13/16	4-7/8	3-5/8
	1-2500 x 1½-300	11-1/16	5-1/8	3-5/8
	1½-150 x 1½-150	9-5/8	3-5/8	2-15/16
	1½-150 x 2-150	9-5/8	3-5/8	3-5/8
	1-150 x 2-150	9-5/8	3-5/8	3-5/8
	1-1500 x 1½-1500			

FOR R.T.J. DIMENSIONS, CONSULT FACTORY

SERIES NO. §	ORIFICE SIZE	SEAT MATERIAL	SET PRESSURE RANGE
1613	.375	PLASTIC ONLY	40 - 3,500

§ SEE PAGE 89 & 90 FOR PART NUMBERING SYSTEM.

SEE PAGE 72 FOR CAPACITY CHART

SUGGESTED SEAT MATERIAL

SET PRESSURE	SEAT MATERIAL
40 - 3,000	TEFLON †
3,000 - 3,500	KEL-F †

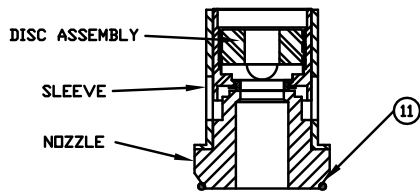

INNER VALVE UNIT DETAIL

† TEMPERATURE RANGE
TEFLON : -450°F TO 500°F
KEL-F : -400°F TO 400°F

† OTHER SPRING MATERIALS
AVAILABLE UPON REQUEST.

WEIGHT IS APPROX. 20#
DEPENDING ON FLANGE SIZE

***IVU FOR .375
C/S OR 316 S/S CLASS IS
303 S/S SLEEVE
316 S/S NOZZLE

ITEM NO.	PART NAME	316 S/S MATERIAL CLASS	CARBON STEEL MATERIAL CLASS
1	HOOD	ASTM A479,TYPE 316	ASME SA29,TYPE 12L14
2	LOCKNUT	ASTM A479,TYPE 316	ASME SA29,TYPE 12L14
3	HOOD SEAL	TEFLON,BUNA-N,VITON	TEFLON,BUNA-N,VITON
4	PRESSURE SCREW	ASTM A479,TYPE 316	ASME SA29,TYPE 12L14
5	SPRING PLATES	ASTM A479,TYPE 316	ASTM A582,TYPE 303
6	SPRING	ASTM A313,TYPE 17/7	ASTM A313,TYPE 17/7
7	SPRING POST	ASTM A479,TYPE 316	ASTM A582,TYPE 303
8	SEAL & WIRE	LEAD SEAL,S/S WIRE	LEAD SEAL,S/S WIRE
9	INNER VALVE UNIT	303 S/S ; 316 S/S	303 S/S ; 316 S/S
10	BONNET	ASME SA351,TYPE CF8M	ASME SA216,TYPE WCB
11	BODY SEAL	TEFLON,BUNA-N,VITON	TEFLON,BUNA-N,VITON
12	BODY	ASME SA351,TYPE CF8M	ASME SA216,TYPE WCB
13	BOLTS (3 REQUIRED)	ASTM A479,TYPE 316	B7