



SAFETY-RELIEF VALVE

MODEL 3900

(SERIES 391 & 392)

LIQUID SERVICE

*ASME (140°F MAX.)
UV CODED

NATIONAL BOARDED

*ASME UV CODED PER SEC. VIII DIV. I
.250 ORIFICE 1/2 X 1/2 CONNECTIONS ONLY

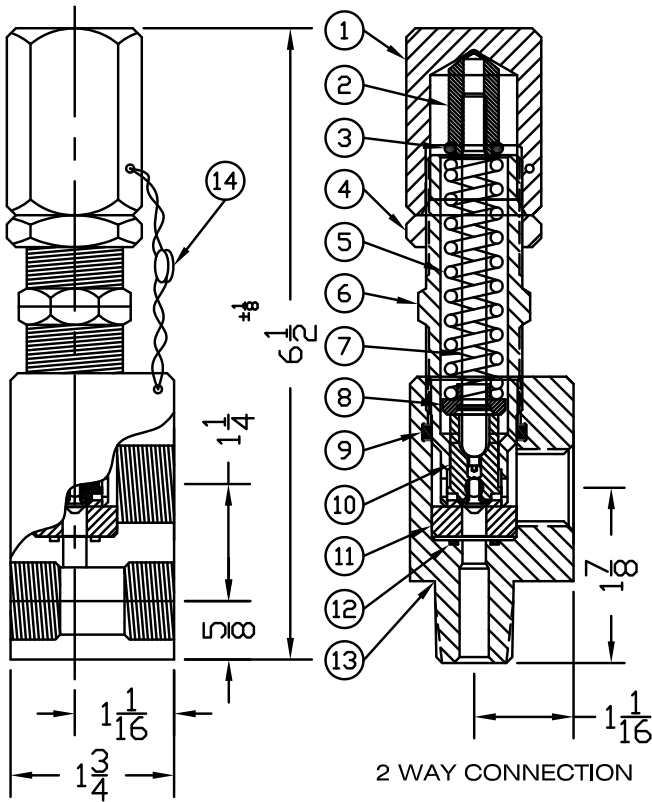

THREAD CONNECTIONS

ORIFICE SIZE	INLET	OUTLET
.187	1/4,3/8,1/2,3/4 MNPT	1/4,3/8,1/2 FNPT
	1/4,3/8,1/2 FNPT	MS33649-4,6,8
	MS33649-4,6,8	3/8 SOCKET WELD
	MS33656-6,8	
	1/4 AUTOCLAVE OR AMINCO	
.250	1/4,3/8,1/2,3/4 MNPT	1/4,3/8,1/2 FNPT
	1/4,3/8,1/2 FNPT	MS33649-4,6,8
	3/8,1/2 SOCKET WELD	3/8 SOCKET WELD
	MS33649-4,6,8	
	MS33656-6,8	
	9/16 AUTOCLAVE	

SERIES NO. §	ORIFICE SIZE	SEAT MATERIAL	MAX. SET PRESSURE
391**	.187	PLASTIC/METAL	6,750
392*	.250	PLASTIC ONLY	2,000

** .187 ORIFICE AT 25% OVERPRESSURE

* .250 ORIFICE AT 10% OVERPRESSURE

3 WAY CONNECTION

WEIGHT IS APPROX. 2-1/2#

SEE PAGE 74 & 75 FOR CAPACITY CHARTS

§ SEE PAGE 91 & 92 FOR PART NUMBERING SYSTEM.

¶ TEMPERATURE RANGE: TEFLON : -450°F TO 500°F
KEL-F : -400°F TO 400°F
VESPEL : -420°F TO 500°F

SUGGESTED SEAT MATERIAL

SET PRESSURE	SEAT MATERIAL
50 - 3,000	TEFLON ¶
3,000 - 5,000	KEL-F ¶
5,000 - 6,750	VESPEL ¶

ITEM NO.	PART NAME	303 S/S MATERIAL CLASS	316 S/S MATERIAL CLASS	CARBON STEEL MATERIAL CLASS
1	HOOD	ASTM A582,TYPE 303	ASTM A479,TYPE 316	ASME SA29,TYPE 12L14
2	SPRING PLUNGER	ASTM A582,TYPE 303	ASTM A479,TYPE 316	ASTM A582,TYPE 303
3	SPRING PLUNGER SEAL	TEFLON,BUNA-N,VITON	TEFLON,BUNA-N,VITON	TEFLON,BUNA-N,VITON
4	LOCKNUT	ASTM A582,TYPE 303	ASTM A479,TYPE 316	ASME SA29,TYPE 12L14
5	SPRING	ASTM A313,TYPE 316	ASTM A313,TYPE 316	ASTM A313,TYPE 316
6	BONNET	ASTM A582,TYPE 303	ASTM A479,TYPE 316	ASTM A582,TYPE 303
7	SPRING POST	ASTM A582,TYPE 303	ASTM A479,TYPE 316	ASTM A582,TYPE 303
8	SPRING PLATE	ASTM A582,TYPE 303	ASTM A479,TYPE 316	ASTM A582,TYPE 303
9	BODY SEAL	TEFLON,BUNA-N,VITON	TEFLON,BUNA-N,VITON	TEFLON,BUNA-N,VITON
10	DISC ASSEMBLY	ASTM A582,TYPE 303	ASTM A479,TYPE 316	ASTM A582,TYPE 303
11	NOZZLE	ASTM A582,TYPE 303	ASTM A479,TYPE 316	ASTM A582,TYPE 303
12	NOZZLE SEAL	TEFLON,BUNA-N,VITON	TEFLON,BUNA-N,VITON	TEFLON,BUNA-N,VITON
13	BODY	ASTM A582,TYPE 303	ASTM A479,TYPE 316	ASME SA29,TYPE 12L14
14	SEAL & WIRE	LEAD SEAL;S/S WIRE	LEAD SEAL;S/S WIRE	LEAD SEAL;S/S WIRE