



# SAFETY-RELIEF VALVE

## MODEL 4200

(SERIES 424 & 425)

FOR LIQUID SERVICE  
AT 25% OVERPRESSURE

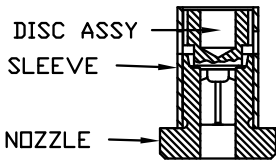
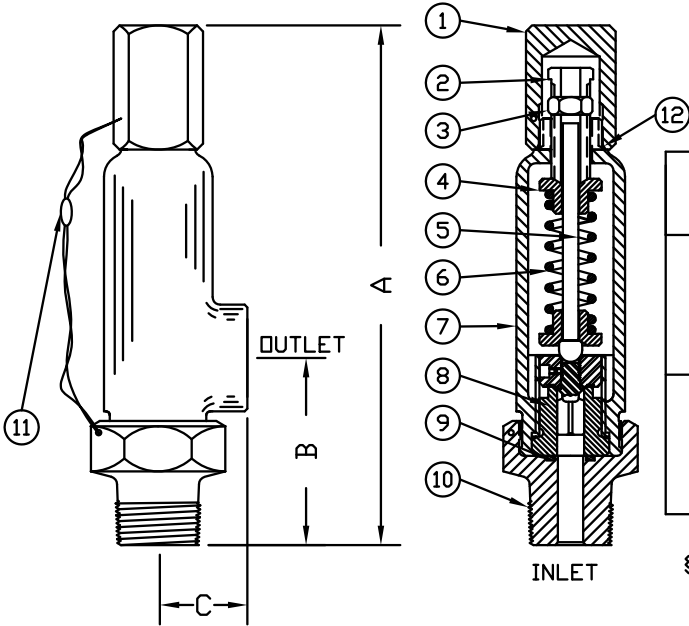

INNER VALVE UNIT DETAIL  
METAL SEAT

### THREAD CONNECTIONS

ORIFICE SIZE	INLET	OUTLET
.375	1/2, 3/4, 1, 1 1/4, 1 1/2, 2 MNPT	3/4, 1, 2 FNPT
	1/2, 3/4, 1, 1 1/4, 1 1/2 FNPT	MS33649-12, 16
	MS33649-8, 10, 12, 16	
	MS33656-12	
.437	3/4, 1, 1 1/4, 1 1/2, 2 MNPT	1, 2 FNPT
	3/4, 1, 1 1/4, 1 1/2 FNPT	MS33649-16
	MS33649-8, 12, 16	
	MS33656-12	

§ SEE PAGE 91 & 92 FOR PART NUMBERING SYSTEM  
SEE PAGE 76 FOR CAPACITY CHARTS.

SERIES NO. §	ORIFICE SIZE	SEAT MATERIAL	SET PRESSURE RANGE
424	.375	METAL ONLY	50 - 9,900
425	.437	METAL ONLY	50 - 3,650

DIMENSIONS	A ±1/8	B ±1/8	C ±1/16	APPROX WEIGHT
1 1/4, 1 1/2, 2" MNPT x 2" FNPT	9"	3-7/8	2-1/8	7#
ALL OTHERS	8-3/8	3"	1-7/16	4-1/2#

BACK PRESSURE SEALS AVAILABLE UPON REQUEST  
I.V.U. FOR .437 C/S CLASS IS 17-4 PH;  
303 S/S; 316 S/S.

† OTHER SPRING MATERIALS UPON REQUEST

ITEM NO.	PART NAME	316 S/S MATERIAL CLASS	BRONZE MATERIAL CLASS	CARBON STEEL MATERIAL CLASS
1	HOOD	ASTM A479, TYPE 316	ASTM B16	ASME SA29, TYPE 12L14
2	PRESSURE SCREW	ASTM A479, TYPE 316	ASTM A582, TYPE 303	ASME SA29, TYPE 12L14
3	LOCKNUT	ASTM A479, TYPE 316	ASTM A582, TYPE 303	ASME SA29, TYPE 12L14
4	SPRING PLATES (2)	ASTM A479, TYPE 316	ASTM A582, TYPE 303	ASTM A582, TYPE 303
5	SPRING POST	ASTM A479, TYPE 316	ASTM A582, TYPE 303	ASTM A582, TYPE 303
6	SPRING †	ASTM A313, TYPE 316	ASTM A313, TYPE 316	ASTM A313, TYPE 316
7	BONNET	ASME A351, TYPE CF8M	ASTM B584, ALLOY 875	ASTM A395
8	INNER VALVE UNIT	ASTM A479, TYPE 316	ASTM A582, TYPE 303	ASTM A582, TYPE 303
9	NOZZLE SEAL	TEFLON, BUNA-N, VITON	TEFLON, BUNA-N, VITON	TEFLON, BUNA-N, VITON
10	BODY	ASTM A479, TYPE 316	ASTM B16	ASME SA29, TYPE 1018
11	SEAL & WIRE	LEAD SEAL; S/S WIRE	LEAD SEAL; COPPER WIRE	LEAD SEAL; COPPER WIRE
12	HOOD SEAL	TEFLON, BUNA-N, VITON	TEFLON, BUNA-N, VITON	TEFLON, BUNA-N, VITON