



INLINE CHECK VALVE

MODEL 2000 - 2100 - 2200 - 2300

DASH NUMBER	MS SIZE*	NPT SIZE	GRAYLOC SIZE	DIMENSIONS			MINIMUM ORIFICE SIZE	APPROX. WEIGHT
				A ±1/16	B ±1/16	C ±1/16		
-12	3/4	3/4	1/2, 3/4	4-3/4	1-7/8	1-3/4	.604	3#
-16	1"	1"	1" GR-4 & -5	5-15/16	2-5/8	2-3/8	.839	7#
-20	1-1/4	1-1/4	1" GR-11,1-1/4,1-1/2	8-15/32	3-1/2	3-1/4	1.073	17#
-24	1-1/2	1-1/2,2	2"	9-7/16	4-1/4	4"	1.307	30#
-32	2"	2-1/2,3	2-1/2,3	11-11/16	5-15/16	5-1/2	1.776	70#
-48		4"	4"	11-11/16	6-3/8	6-1/8	1.776	84#

*ALL AREAS EQUAL TO OR GREATER THAN MS33649 TUBING OF SAME SIZE

CHECK VALVES ARE WITH STANDARD 3 PSIG MAX. CRACK SPRING. OTHER CRACKS AVAILABLE UPON REQUEST.

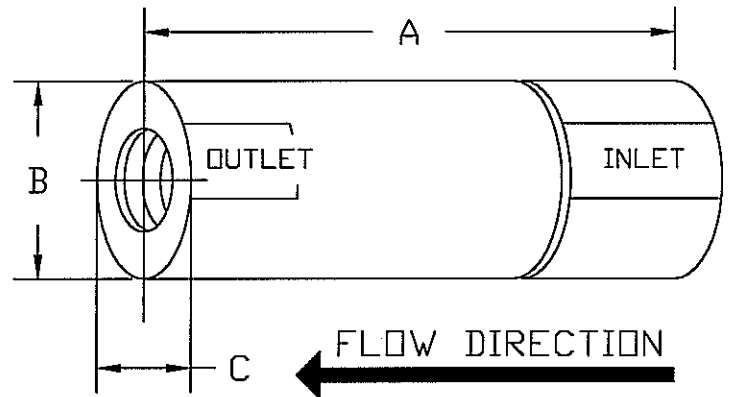
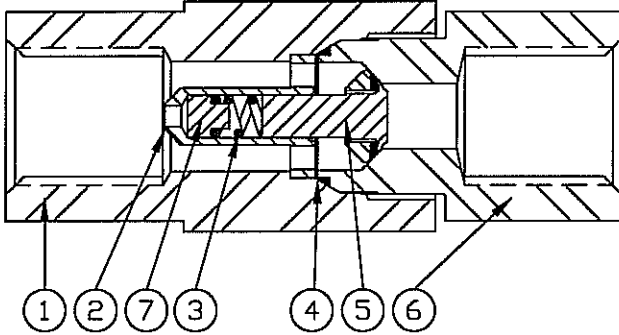

ITEM NUMBER	PART NAME	MATERIAL CLASS
1	BODY	ASTM A479 TYPE 316
2	CAGE	ASTM A479 TYPE 316
3	SPRING	ASTM A313,TYPE 316
4	SEAL	TEFLON, BUNA-N OR VITON
5	DISC ASSEMBLY	§ ASTM A479 TYPE 316
6	BASE	ASTM A479 TYPE 316
7	SPRING PLATE	ASTM A479 TYPE 316

§ WITH TEFLON, KEL-F, VESPEL OR METAL SEATS

§ ALSO AVAILABLE IN 'O' RING DESIGN FOR 3,000 WOG MAX.

OTHER MATERIAL CLASSES AVAILABLE UPON REQUEST.

SEE PAGE 86 FOR HEAD LOSS CURVES AND Cv CHART.

SEE PAGE 93 & 94 FOR PART NUMBERING SYSTEM.

ALTERNATE END CONNECTIONS

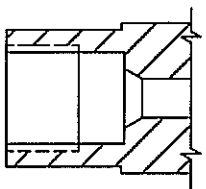

AMINCO

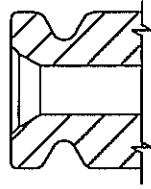

GRAYLOC

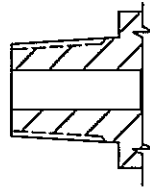

MALE NPT

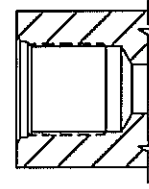

MS33649

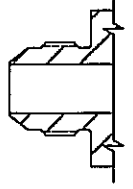

MS33656