

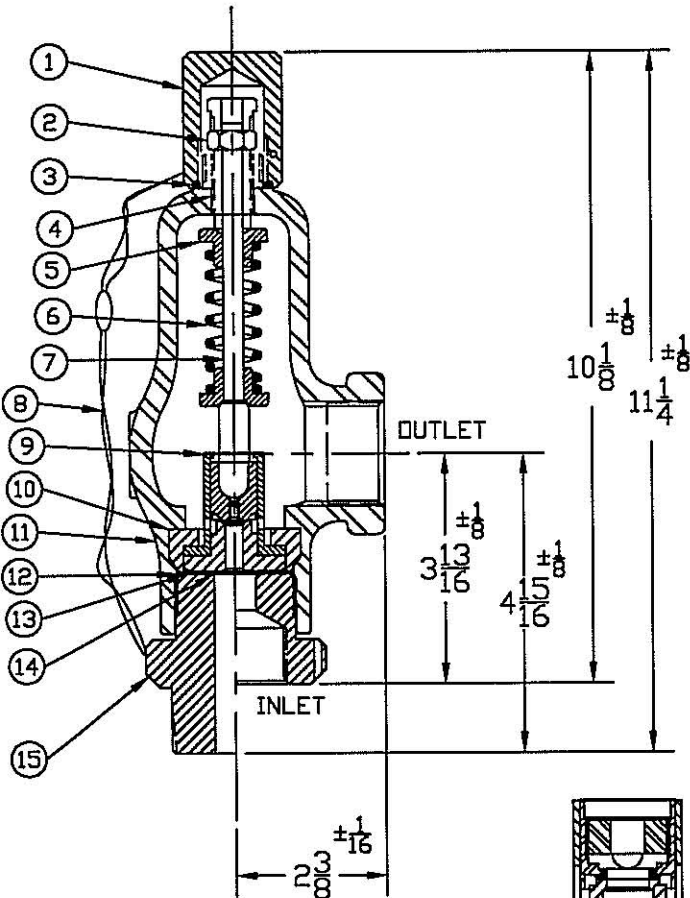

SAFETY-RELIEF VALVE MODEL 1500

(SERIES 1524,1525)

FOR AIR & GAS SERVICE
AT 10% OVERPRESSURE
METAL SEATS ONLY



THREAD CONNECTIONS

ORIFICE SIZE	INLET	OUTLET
.500 & .625	1, 1¼, 1½ MNPT	1, 1½ FNPT
	1, 1¼, 1½ FNPT	MS33649-16,24
	MS33649-16,20,24 GRAYLOC	GRAYLOC
	MS33656-16,24	
	1' AUTOCLAVE	

SERIES NO. §	ORIFICE SIZE	SEAT MATERIAL	SET PRESSURE RANGE
1524	.500	METAL ONLY	40 - 1,000
1525	.625	METAL ONLY	40 - 1,000

§ SEE PAGE 89 & 90 FOR PART NUMBERING SYSTEM.

WEIGHT IS APPROX. 12#

***IVU FOR .250 & .375
C/S OR 316 S/S CLASS IS
303 S/S SLEEVE
316 S/S NOZZLE

† OTHER SPRING MATERIALS
AVAILABLE UPON REQUEST.

INNER VALVE UNIT
(.500 & .625)

ITEM NO.	PART NAME	316 S/S MATERIAL CLASS	CARBON STEEL MATERIAL CLASS
1	HOOD	ASTM A479,TYPE 316	ASME SA29,TYPE 12L14
2	LOCKNUT	ASTM A479,TYPE 316	ASTM A582,TYPE 303
3	HOOD SEAL	TEFLON,BUNA-N,VITON	TEFLON,BUNA-N,VITON
4	PRESSURE SCREW	ASTM A479,TYPE 316	ASTM A582,TYPE 303
5	SPRING PLATES	ASTM A479,TYPE 316	ASTM A582,TYPE 303
6	SPRING	ASTM A313,TYPE 17/7	ASTM A313,TYPE 17/7
7	SPRING POST	ASTM A479,TYPE 316	ASTM A582,TYPE 303
8	SEAL & WIRE	LEAD SEAL/S/S WIRE	LEAD SEAL/S/S WIRE
9	INNER VALVE UNIT***	ASTM A479,TYPE 316	ASTM A479,TYPE 316
10	BONNET	ASME SA351,TYPE CF8M	ASME SA216,TYPE WCB
11	BODY SEAL	TEFLON,BUNA-N,VITON	TEFLON,BUNA-N,VITON
12	GASKET	TEFLON	TEFLON
13	BODY	ASTM A479,TYPE 316	ASME SA29,TYPE 1018

†