



SAFETY-RELIEF VALVE

MODEL 1500

(SERIES 1534, 1535, 1536 & 1537)

***ASME
UV CODED
NATIONAL BOARDED**

*ASME UV CODED PER SEC. VIII DIV. I
AIR & GAS SERVICE. (PLASTIC SEATS ONLY)

AIR SERVICE MUST HAVE LIFT LEVER
SEE PAGE 60 FOR LIFTING DEVICES

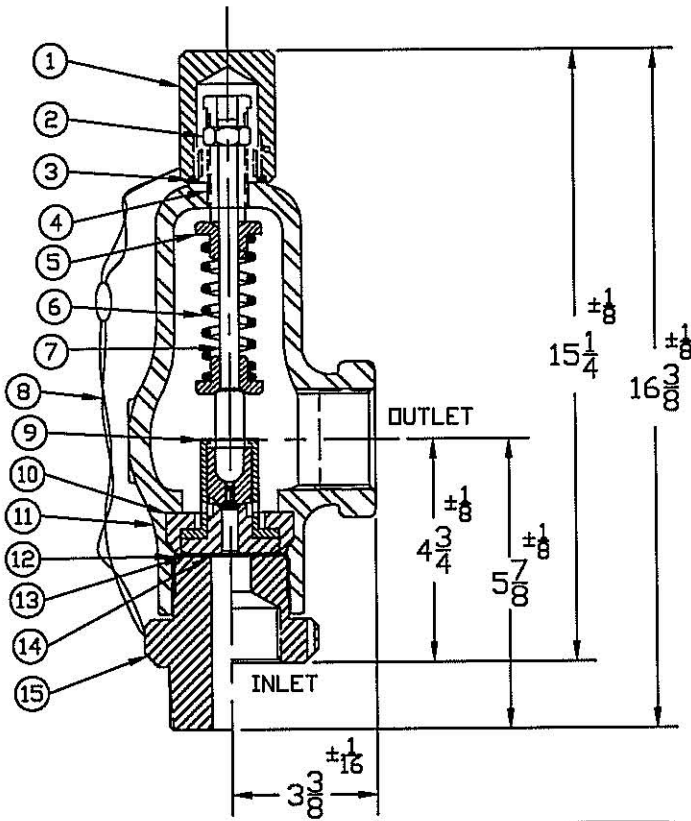

THREAD CONNECTIONS		
* ORIFICE SIZE	INLET	OUTLET
.500 * & .625 *	1, 1 1/4, 1 1/2, 2 MNPT OR FNPT	1 1/2, 2, 2 1/2 FNPT
	MS33649-16,20,24,28,32	MS33649-24,32
.800 * & 1.000 *	1 1/4, 1 1/2, 2 MNPT OR FNPT	2, 2 1/2 FNPT
	MS33649-20,24,28,32	MS33649-24,32
	MS33656-16,20,24,32 GR	GRAYLOC
	MS33656-24,32 GRAYLOC	GRAYLOC

SEE PAGE 23 & 24 FOR CAPACITY CHART

SERIES NO. §	ORIFICE SIZE	SEAT MATERIAL	SET PRESSURE RANGE
* 1534	.500	PLASTIC ONLY	40 - *7,500/8,000
* 1535	.625	PLASTIC ONLY	40 - 6,000
* 1536	.800	PLASTIC ONLY	40 - 3,300
* 1537	1.000	PLASTIC ONLY	40 - 2,130

§ SEE PAGE 89 & 90 FOR PART NUMBERING SYSTEM.

SUGGESTED SEAT MATERIAL

SET PRESSURE	SEAT MATERIAL
40 - 3,000	TEFLON †
3,000 - 5,000	KEL-F †
5,000 - 7,500	VESPEL †

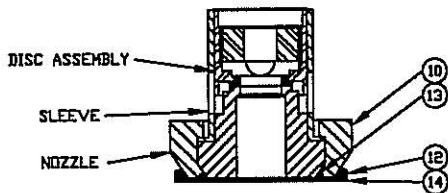

INNER VALVE UNIT
WITH RETAINER RING
(.500 & .625)

WEIGHT IS APPROX. 30#

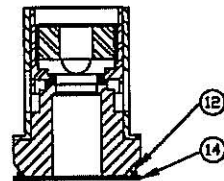

INNER VALVE UNIT
(.800 & 1.000)

† TEMPERATURE RANGE
TEFLON : -450°F TO 500°F
KEL-F : -400°F TO 400°F
VESPEL : -420°F TO 500°F

† OTHER SPRING MATERIALS
AVAILABLE UPON REQUEST.

† USE RETAINER & RETAINER
SEAL FOR THESE INNER
VALVE UNITS ONLY.

ITEM NO.	PART NAME	316 S/S MATERIAL CLASS	BRONZE MATERIAL CLASS	CARBON STEEL MATERIAL CLASS
1	HOOD	ASTM A479,TYPE 316	ASTM B16	ASME SA29,TYPE 12L14
2	LOCKNUT	ASTM A479,TYPE 316	ASTM A582,TYPE 303	ASTM A582,TYPE 303
3	HOOD SEAL	TEFLON,BUNA-N,VITON	TEFLON,BUNA-N,VITON	TEFLON,BUNA-N,VITON
4	PRESSURE SCREW	ASTM A479,TYPE 316	ASTM A582,TYPE 303	ASTM A582,TYPE 303
5	SPRING PLATES	ASTM A479,TYPE 316	ASTM A582,TYPE 303	ASTM A582,TYPE 303
† 6	SPRING	ASTM A313,TYPE 17/7	ASTM A313,TYPE 17/7	ASTM A313,TYPE 17/7
7	SPRING POST	ASTM A479,TYPE 316	ASTM A582,TYPE 303	ASTM A582,TYPE 303
8	SEAL & WIRE	LEAD SEAL'S/S WIRE	LEAD SEAL'S/S WIRE	LEAD SEAL'S/S WIRE
9	INNER VALVE UNIT	ASTM A479,TYPE 316	ASTM A479,TYPE 316	ASTM A479,TYPE 316
† 10	RETAINER	ASTM A479,TYPE 316	ASTM A582,TYPE 303	ASTM A582,TYPE 303
11	BONNET	ASME SA351,TYPE CF8M	ASTM B584,ALLOY B75	ASME SA216,TYPE WCB
12	BODY SEAL	TEFLON,BUNA-N,VITON	TEFLON,BUNA-N,VITON	TEFLON,BUNA-N,VITON
† 13	RETAINER SEAL	TEFLON,BUNA-N,VITON	TEFLON,BUNA-N,VITON	TEFLON,BUNA-N,VITON
14	GASKET	TEFLON	TEFLON	TEFLON
15	BODY	ASTM A479,TYPE 316	ASTM B16	ASME SA29,TYPE 1018