

SAFETY-RELIEF VALVE

MODEL 1500

(SERIES 1534,1535,1536 & 1537)

FOR GAS & AIR SERVICE
AT 10% OVERPRESSURE
METAL SEATS ONLY

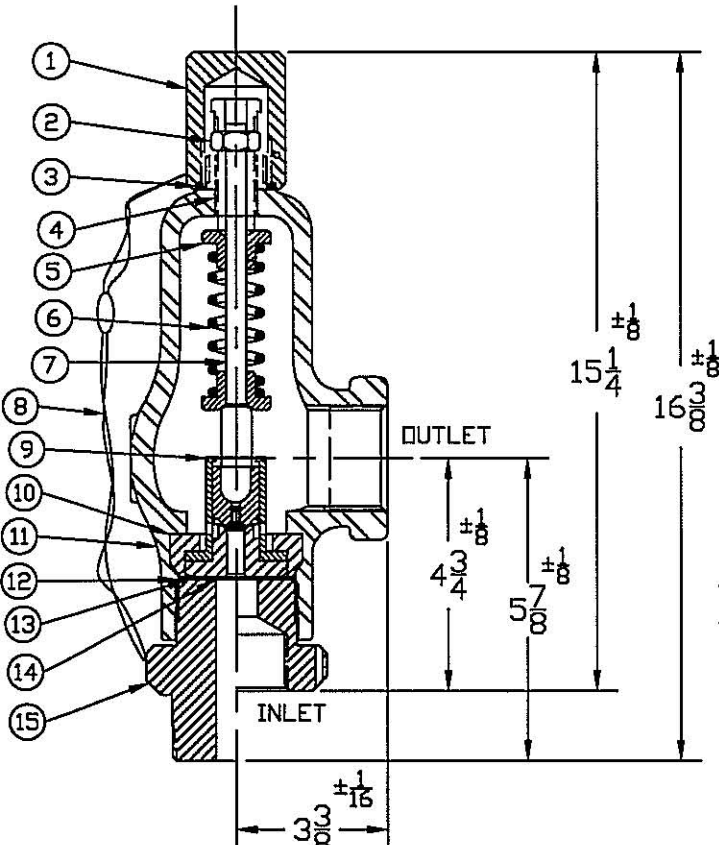

THREAD CONNECTIONS

ORIFICE SIZE	INLET	OUTLET
.500 & .625	1, 1½, 1¾, 2 MNPT OR FNPT	1½, 2, 2½ FNPT
	MS33649-16,20,24,28,32	MS33649-24,32
	MS33656-16,20,24,32 GR	GRAYLOC
.800 & 1.000	1¾, 1½, 2 MNPT OR FNPT	2, 2½ FNPT
	MS33649-20,24,28,32	MS33649-24,32
	MS33656-24,32 GRAYLOC	GRAYLOC

SERIES NO. §	ORIFICE SIZE	SEAT MATERIAL	SET PRESSURE RANGE
1534	.500	METAL ONLY	40 - 1,000
1535	.625	METAL ONLY	40 - 1,000
1536	.800	METAL ONLY	40 - 1,000
1537	1.000	METAL ONLY	40 - 1,000

§ SEE PAGE 89 & 90 FOR PART NUMBERING SYSTEM.

WEIGHT IS APPROX. 30#

‡ OTHER SPRING MATERIALS AVAILABLE UPON REQUEST.

† USE RETAINER & RETAINER SEAL FOR THESE INNER VALVE UNITS ONLY.

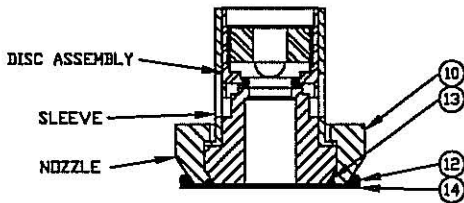

INNER VALVE UNIT WITH RETAINER RING (.500 & .625)

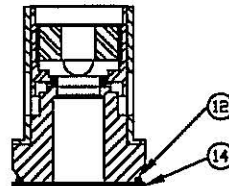

INNER VALVE UNIT (.800 & 1.000)

ITEM NO.	PART NAME	316 S/S MATERIAL CLASS	BRONZE MATERIAL CLASS	CARBON STEEL MATERIAL CLASS
1	HOOD	ASTM A479,TYPE 316	ASTM B16	ASME SA29,TYPE 12L14
2	LOCKNUT	ASTM A479,TYPE 316	ASTM A582,TYPE 303	ASTM A582,TYPE 303
3	HOOD SEAL	TEFLON,BUNA-N,VITON	TEFLON,BUNA-N,VITON	TEFLON,BUNA-N,VITON
4	PRESSURE SCREW	ASTM A479,TYPE 316	ASTM A582,TYPE 303	ASTM A582,TYPE 303
5	SPRING PLATES	ASTM A479,TYPE 316	ASTM A582,TYPE 303	ASTM A582,TYPE 303
‡	6 SPRING	ASTM A313,TYPE 17/7	ASTM A313,TYPE 17/7	ASTM A313,TYPE 17/7
7	SPRING POST	ASTM A479,TYPE 316	ASTM A582,TYPE 303	ASTM A582,TYPE 303
8	SEAL & WIRE	LEAD SEAL/S/S WIRE	LEAD SEAL/S/S WIRE	LEAD SEAL/S/S WIRE
9	INNER VALVE UNIT	ASTM A479,TYPE 316	ASTM A479,TYPE 316	ASTM A479,TYPE 316
†	10 RETAINER	ASTM A479,TYPE 316	ASTM A582,TYPE 303	ASTM A582,TYPE 303
11	BONNET	ASME SA351,TYPE CF8M	ASTM B584,ALLOY 875	ASME SA216,TYPE WCB
‡	12 BODY SEAL	TEFLON,BUNA-N,VITON	TEFLON,BUNA-N,VITON	TEFLON,BUNA-N,VITON
13	RETAINER SEAL	TEFLON,BUNA-N,VITON	TEFLON,BUNA-N,VITON	TEFLON,BUNA-N,VITON
14	GASKET	TEFLON	TEFLON	TEFLON
15	BODY	ASTM A479,TYPE 316	ASTM B16	ASME SA29,TYPE 1018