

SAFETY-RELIEF VALVE

MODEL 1500

(SERIES 1513 & 1519)

FOR LIQUID SERVICE
AT 10% OVERPRESSURE

**THESE DIMENSIONS ARE GOOD FOR
1" FNPT & MS33649-16 ALSO.

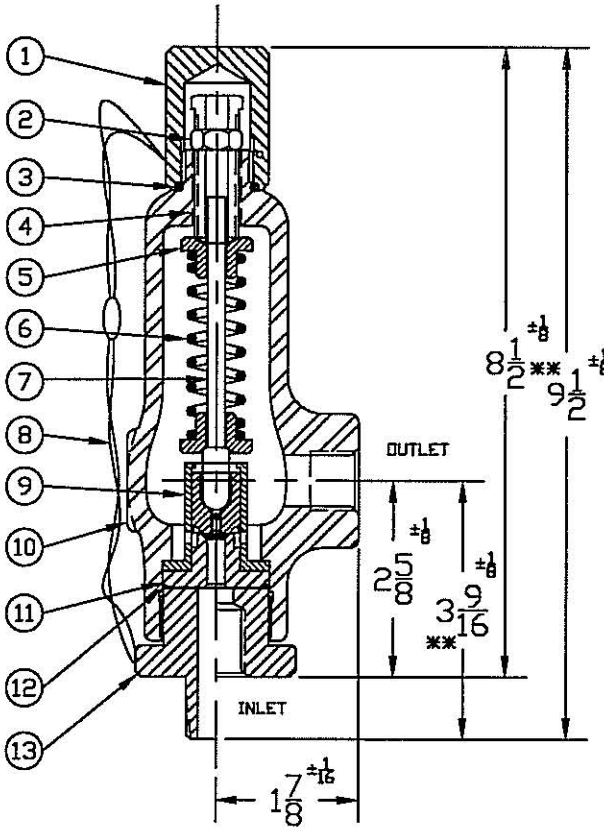

THREAD CONNECTIONS

ORIFICE SIZE	INLET	OUTLET
.187	1/4, 3/8, 1/2, 3/4, 1" FNPT	1/2, 3/4, 1" FNPT
	1/4, 3/8, 1/2, 3/4, 1" MNPT	MS33649-4, 6, 8, 12, 16
	MS33649-4, 6, 8, 10, 12, 16	
	MS33656-8, 10, 12, 16	
	1/4, 9/16, 1" M.P. AUTOCLAVE	
	1/4, 9/16, 1" H.P. AMINCO	
.375	GRAYLOC	GRAYLOC
	3/4, 1" FNPT	1" FNPT
	3/4, 1" MNPT	MS33649-16
	MS33649-12, 16 GRAYLOC	MS16142-16, 1" FLPT
	MS33656-12, 16 3/4, 1" AUTOCLAVE	GRAYLOC

SERIES NO. §	ORIFICE SIZE	SEAT MATERIAL	SET PRESSURE RANGE
1519	.187	PLASTIC ONLY	40 - 15,000
1513	.375	PLASTIC ONLY	40 - 3,500

SUGGESTED SEAT MATERIAL

SET PRESSURE	SEAT MATERIAL
40 - 3,000	TEFLON †
3,000 - 5,000	KEL-F †
5,000 - 15,000	VESPEL †

§ SEE PAGE 89 & 90 FOR PART NUMBERING SYSTEM.

SEE PAGE 72 & 73 FOR CAPACITY CHART

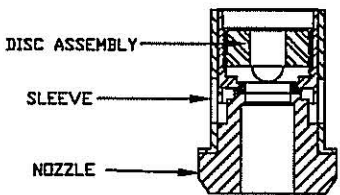

INNER VALVE UNIT

† OTHER SPRING MATERIALS
AVAILABLE UPON REQUEST.

WEIGHT IS APPROX. 7#

‡ TEMPERATURE RANGE
TEFLON : -450°F TO 500°F
KEL-F : -400°F TO 400°F

***IVU FOR .375
C/S OR 316 S/S CLASS HAS
303 S/S SLEEVE
316 S/S NOZZLE

ITEM NO.	PART NAME	316 S/S MATERIAL CLASS	CARBON STEEL MATERIAL CLASS
1	HOOD	ASTM A479, TYPE 316	ASME SA29, TYPE 12L14
2	LOCKNUT	ASTM A479, TYPE 316	ASTM A582, TYPE 303
3	HOOD SEAL	TEFLON, BUNA-N, VITON	TEFLON, BUNA-N, VITON
4	PRESSURE SCREW	ASTM A479, TYPE 316	ASTM A582, TYPE 303
5	SPRING PLATES	ASTM A479, TYPE 316	ASTM A582, TYPE 303
6	SPRING	ASTM A313, TYPE 17/7	ASTM A313, TYPE 17/7
7	SPRING POST	ASTM A479, TYPE 316	ASTM A582, TYPE 303
8	SEAL & WIRE	LEAD SEAL/S/S WIRE	LEAD SEAL/S/S WIRE
9	INNER VALVE UNIT***	ASTM A479, TYPE 316	ASTM A479, TYPE 316
10	BONNET	ASME SA351, TYPE CF8M	ASME SA216, TYPE WCB
11	BODY SEAL	TEFLON, BUNA-N, VITON	TEFLON, BUNA-N, VITON
12	GASKET	TEFLON	TEFLON
13	BODY	ASME SA351, TYPE CF8M	ASME SA29, TYPE 1018