

SAFETY-RELIEF VALVE MODEL 1600

(SERIES 1623, 1624 & 1625)

FOR AIR & GAS SERVICE
AT 10% OVERPRESSURE
METAL SEATS ONLY

R.F. FLANGE DIMENSIONS

ORIFICE SIZE	INLET	OUTLET	A ±1/8	B ±1/8	C ±1/16
.375 & .500	1-150	2-150 OR 2½-150	11-1/16	4-7/8	6
	1-300		11-1/16	4-7/8	6
	1-600		11-1/16	4-7/8	6
	1½-150		11-1/16	4-7/8	6
	1½-300		11-1/16	4-7/8	6
	1½-600		11-1/16	4-7/8	6
	1½-900	2-300	11-1/16	4-7/8	6
	1½-1500	OR	11-1/16	4-7/8	6
	1½-2500	2½-300	11-3/4	5-1/2	6
	2-150	2-150	11-1/16	4-7/8	6
	2-300	OR	11-1/16	4-7/8	6
	2-600	2½-150	11-1/16	4-7/8	6

FOR R.T.J. DIMENSIONS, CONSULT FACTORY

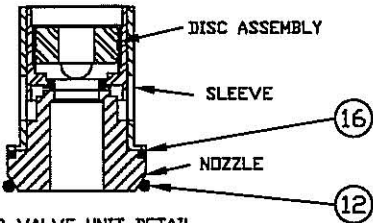
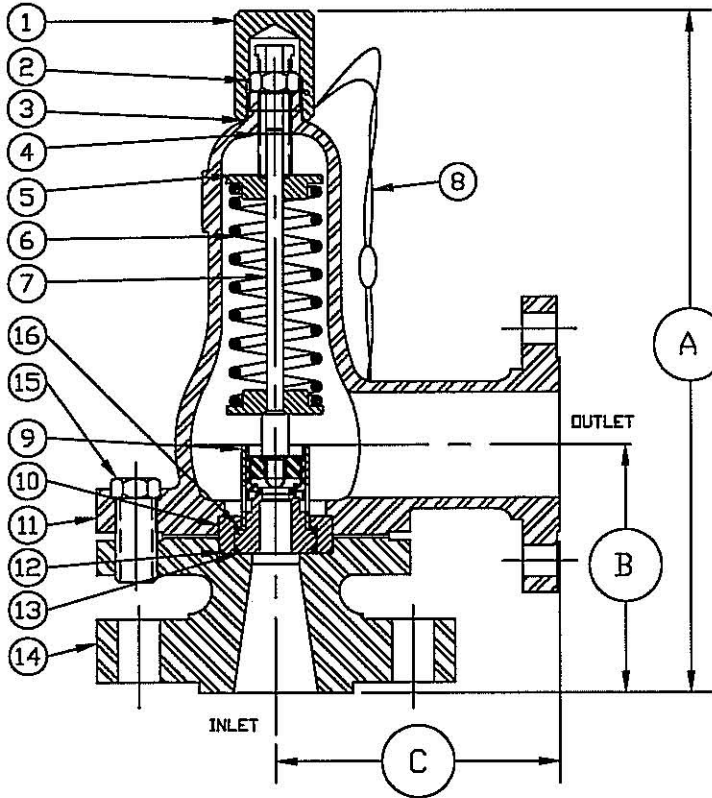

INNER VALVE UNIT DETAIL
.500 & .625

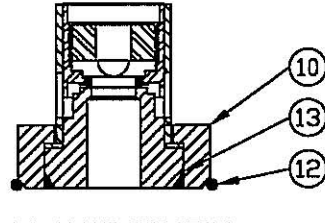

INNER VALVE UNIT DETAIL
.250 & .375

SERIES NO. §	ORIFICE SIZE	SEAT MATERIAL	SET PRESSURE RANGE
1623	.375	METAL ONLY	40 - 1,000
1624	.500	METAL ONLY	40 - 1,000
1625	.625	METAL ONLY	40 - 1,000

§ SEE PAGE 89 & 90 FOR PART NUMBERING SYSTEM.

ITEM NO.	PART NAME	316 S/S MATERIAL CLASS	CARBON STEEL MATERIAL CLASS
1	HOOD	ASTM A479,TYPE 316	ASME SA29,TYPE 12L14
2	LOCKNUT	ASTM A479,TYPE 316	ASTM A582,TYPE 303
3	HOOD SEAL	TEFLON,BUNA-N,VITON	TEFLON,BUNA-N,VITON
4	PRESSURE SCREW	ASTM A479,TYPE 316	ASTM A582,TYPE 303
5	SPRING PLATES	ASTM A479,TYPE 316	ASTM A582,TYPE 303
6	SPRING	ASTM A313,TYPE 17/7	ASTM A313,TYPE 17/7
7	SPRING POST	ASTM A479,TYPE 316	ASTM A582,TYPE 303
8	SEAL & WIRE	LEAD SEAL,S/S WIRE	LEAD SEAL,S/S WIRE
9	INNER VALVE UNIT***	303 S/S , 316 S/S	303 S/S , 316 S/S
10	RETAINER RING	ASTM A479,TYPE 316	ASTM A582,TYPE 303
11	BONNET	ASME A351,TYPE CF8M	ASME SA216,TYPE WCB
12	BODY SEAL	TEFLON,BUNA-N,VITON	TEFLON,BUNA-N,VITON
13	RETAINER SEAL	TEFLON,BUNA-N,VITON	TEFLON,BUNA-N,VITON
14	BODY	ASME A351,TYPE CF8M	ASME SA216,TYPE WCB
15	BOLTS (3 REQUIRED)	ASTM A479,TYPE 316	B7
16	B.P. SEAL	TEFLON,BUNA-N,VITON	TEFLON,BUNA-N,VITON

† OTHER SPRING MATERIALS AVAILABLE UPON REQUEST.

WEIGHT IS APPROX. 35#
DEPENDING ON FANGE SIZE

***.250 & .375 ORIFICE HAS
303 S/S SLEEVE,
316 S/S NOZZLE