

# INLINE CHECK VALVE

MODEL 2000 - 2100 - 2200 - 2300

DASH NUMBER	MS SIZE*	NPT SIZE	DIMENSIONS			MINIMUM ORIFICE SIZE	APPROX. WEIGHT
			A ±1/16	B ±1/16	C ±1/16		
-04	1/4	1/8	2-27/32	1"	7/8	.230	1/2#
-05	5/16	1/4	2-27/32	1"	7/8	.230	1/2#
-06	3/8	3/8	3-5/16	1-1/8	1"	.293	3/4#
-08	1/2	1/2	3-11/16	1-3/8	1-1/4	.387	1#

\*ALL AREAS EQUAL TO OR GREATER THAN MS33649 TUBING OF SAME SIZE

CHECK VALVES ARE WITH STANDARD 3 PSIG MAX. CRACK SPRING. OTHER CRACKS AVAILABLE UPON REQUEST.

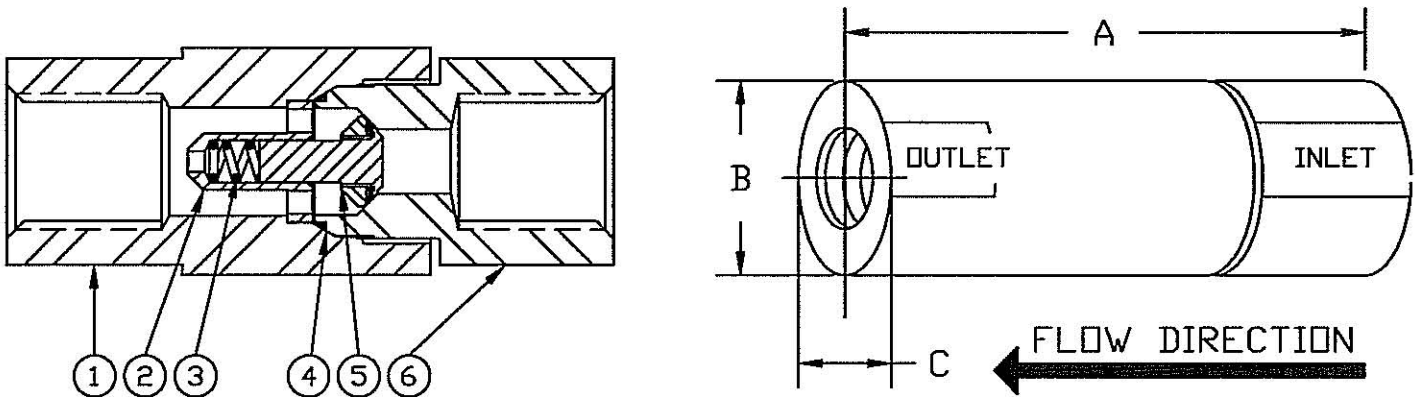

ITEM NUMBER	PART NAME	MATERIAL CLASS
1	BODY	ASTM A479 TYPE 316
2	CAGE	ASTM A479 TYPE 316
3	SPRING	ASTM A313 TYPE 316
4	SEAL	TEFLON, BUNA-N OR VITON
5	DISC ASSEMBLY	§ ASTM A479 TYPE 316
6	BASE	ASTM A479 TYPE 316

§ WITH TEFLON, KEL-F, VESPEL OR METAL SEATS

§ ALSO AVAILABLE IN "O" RING DESIGN FOR 3,000 WOG MAX.

OTHER MATERIAL CLASSES AVAILABLE UPON REQUEST.

SEE PAGE 86 FOR HEAD LOSS CURVES AND CV CHART.

SEE PAGE 93 & 94 FOR PART NUMBERING SYSTEM.

## ALTERNATE END CONNECTIONS

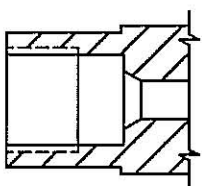

AMINCO

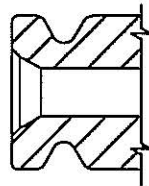

GRAYLOC

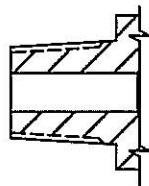

MALE NPT

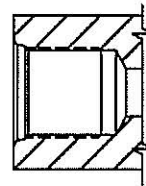

MS33649

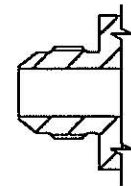

MS33656