



SAFETY-RELIEF VALVE

MODEL 4000

(SERIES 404, 405 & 406)

FOR AIR & GAS SERVICE
AT 10% OVERPRESSURE
METAL SEATS ONLY

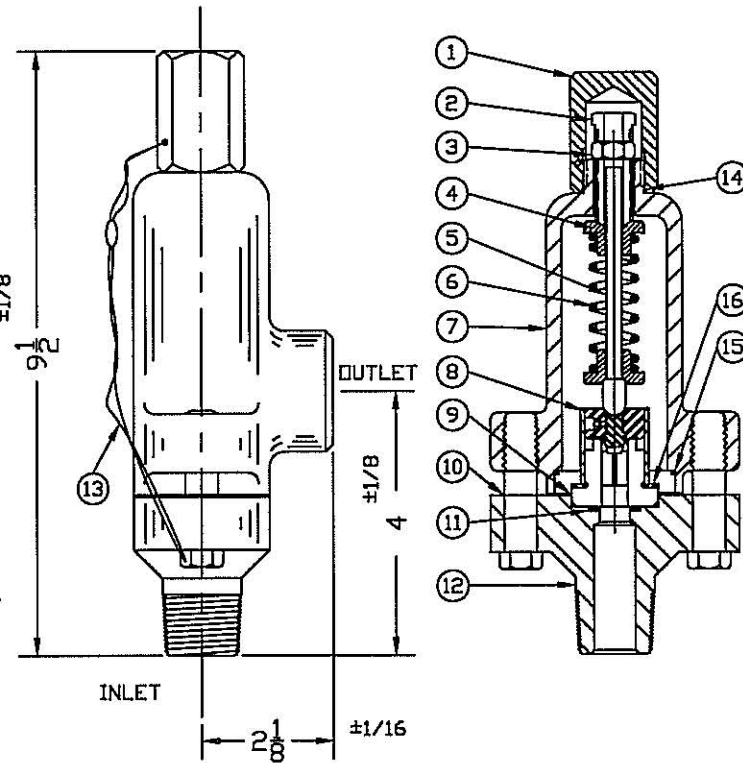

THREAD CONNECTIONS

ORIFICE SIZE	INLET	OUTLET
.375 & .437	3/4, 1, 1 1/4, 1 1/2 MNPT	1, 1 1/4, 1 1/2 FNPT
	3/4, 1 FNPT	MS33649-16, 24
	MS33649-12, 16	1 SOCKET WELD
	3/4, 1 SOCKET WELD	
.500	1, 1 1/4, 1 1/2 MNPT	1, 1 1/4, 1 1/2 FNPT
	1 FNPT	MS33649-16, 24
	MS33649-16	1 SOCKET WELD
	1 SOCKET WELD	

SERIES NO. §	ORIFICE SIZE	SEAT MATERIAL	SET PRESSURE RANGE
404	.375	METAL ONLY	50 - 9,900
405	.437	METAL ONLY	50 - 3,650
406	.500	METAL ONLY	50 - 2,000

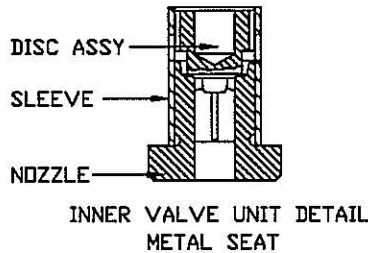

§SEE PAGE 91 & 92 FOR
PART NUMBERING SYSTEM.

WEIGHT IS APPROX. 8#

† OTHER SPRING MATERIALS
UPON REQUEST.

ITEM NO.	PART NAME	BRONZE MATERIAL CLASS	316 S/S MATERIAL CLASS	CARBON STEEL MATERIAL CLASS
1	HOOD	ASTM B16	ASTM A479, TYPE 316	ASME SA29, TYPE 12L14
2	PRESSURE SCREW	ASTM A582, TYPE 303	ASTM A479, TYPE 316	ASTM A582, TYPE 303
3	LOCKNUT	ASTM A582, TYPE 303	ASTM A479, TYPE 316	ASTM A582, TYPE 303
4	SPRING PLATES (2)	ASTM A582, TYPE 303	ASTM A479, TYPE 316	ASTM A582, TYPE 303
5	SPRING POST	ASTM A582, TYPE 303	ASTM A479, TYPE 316	ASTM A582, TYPE 303
6	SPRING	ASTM A313, TYPE 316	ASTM A313, TYPE 316	ASTM A313, TYPE 316
7	BONNET	ASTM B584, ALLOY 875	ASME A351, TYPE CF8M	ASME SA216, TYPE WCB
8	INNER VALVE UNIT	ASTM A582, TYPE 303	ASTM A479, TYPE 316	ASTM A582, TYPE 303
9	RETAINER RING	ASTM A582, TYPE 303	ASTM A479, TYPE 316	ASTM A582, TYPE 303
10	BOLTS (2)	ASTM B16	ASTM A479, TYPE 316	ASME SA29, TYPE 12L14
11	NOZZLE SEAL	TEFLON, BUNA-N, VITON	TEFLON, BUNA-N, VITON	TEFLON, BUNA-N, VITON
12	BODY	ASTM B584, ALLOY 875	ASME A351, TYPE CF8M	ASME SA216, TYPE WCB
13	SEAL & WIRE	LEAD SEAL, COPPER WIRE	LEAD SEAL, S/S WIRE	LEAD SEAL, COPPER WIRE
14	HOOD SEAL	TEFLON, BUNA-N, VITON	TEFLON, BUNA-N, VITON	TEFLON, BUNA-N, VITON
15	RETAINER RING SEAL	TEFLON	TEFLON	TEFLON
16	BACK PRESSURE SEAL	TEFLON	TEFLON	TEFLON