

SAFETY-RELIEF VALVE

MODEL 4200

(SERIES 422, 423 & 425)

***ASME
UV CODED
NATIONAL BOARDED**

* ASME UV CODED PER SEC. VIII DIV. I
AIR & GAS SERVICE (PLASTIC SEATS ONLY)

AIR SERVICE MUST HAVE LIFT LEVER
SEE PAGE 60 FOR LIFTING DEVICES

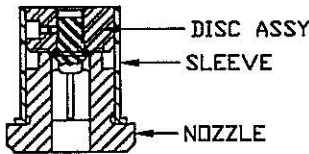
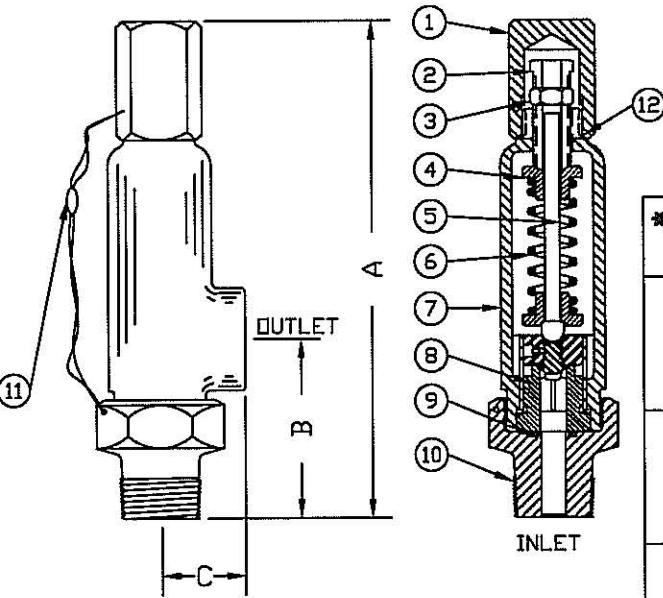

INNER VALVE UNIT DETAIL
PLASTIC SEAT

THREAD CONNECTIONS

*ORIFICE SIZE	INLET	OUTLET
.250	1/2, 3/4, 1, 1 1/4, 1 1/2, 2 MNPT	1/4, 1/2, 3/4, 1, 2 FNPT
	1/4, 3/8, 1/2, 3/4, 1 FNPT	MS33649-8, 12, 16
	1/4, 3/8, 9/16 AMINCO	MS33649-4, 6, 8, 12, 16
.312 *	1/2, 3/4, 1, 1 1/4, 1 1/2, 2 MNPT	3/4, 1, 2 FNPT
	1/2, 3/4, 1, 1 1/4, 1 1/2 FNPT	MS33649-12, 16
	MS33649-8, 10, 12, 16	MS33656-12
.437 *	3/4, 1, 1 1/4, 1 1/2, 2 MNPT	1, 2 FNPT
	3/4, 1, 1 1/4, 1 1/2 FNPT	**MS33649-16
	MS33649-8, 12, 16	CAN'T HAVE CONE ON
	MS33656-12	MS33656-16 ADAPTER

**425 RELIEF VALVE WITH MS33649-16 OUTLET
MUST USE MS33656-16 WITH NO CONE

DIMENSIONS	A ±1/8	B ±1/8	C ±1/16	APPROX WEIGHT
1 1/4, 1 1/2, 2" MNPT x 2" FNPT	9"	3-7/8"	2-1/8"	7#
ALL OTHERS	8-3/8"	3"	1-7/16"	4-1/2#

SERIES NO. §	ORIFICE SIZE	SEAT MATERIAL	SET PRESSURE RANGE
422	.250	PLASTIC ONLY	50 - 11,800
*423	.312	PLASTIC ONLY	50 - *6,000/6,500
*425	.437	PLASTIC ONLY	50 - *3,500/3,650

SUGGESTED SEAT MATERIAL

SET PRESSURE	SEAT MATERIAL
50 - 3,000	TEFLON †
3,000 - 5,000	KEL-F †
5,000 - 11,800	VESPEL †

SEE PAGE 51 & 52 FOR CAPACITY CHARTS
† OTHER SPRING MATERIALS UPON REQUEST
§ SEE PAGE 91 & 92 FOR PART NUMBERING SYSTEM
BACK PRESSURE SEALS AVAILABLE UPON REQUEST
I.V.U. FOR .437 C/S CLASS IS 17-4 PH;
303 S/S, 316 S/S.

† TEMPERATURE RANGE: TEFLON : -450°F TO 500°F
KEL-F : -400°F TO 400°F
VESPEL : -420°F TO 500°F

ITEM NO.	PART NAME	316 S/S MATERIAL CLASS	BRONZE MATERIAL CLASS	CARBON STEEL MATERIAL CLASS
1	HOOD	ASTM A479, TYPE 316	ASTM B16	ASME SA29, TYPE 12L14
2	PRESSURE SCREW	ASTM A479, TYPE 316	ASTM A582, TYPE 303	ASTM A582, TYPE 303
3	LOCKNUT	ASTM A479, TYPE 316	ASTM A582, TYPE 303	ASTM A582, TYPE 303
4	SPRING PLATES (2)	ASTM A479, TYPE 316	ASTM A582, TYPE 303	ASTM A582, TYPE 303
5	SPRING POST	ASTM A479, TYPE 316	ASTM A582, TYPE 303	ASTM A582, TYPE 303
6	SPRING †	ASTM A313, TYPE 316	ASTM A313, TYPE 316	ASTM A313, TYPE 316
7	BONNET	ASME A351, TYPE CF8M	ASTM B584, ALLOY 875	ASTM A395
8	INNER VALVE UNIT	ASTM A479, TYPE 316	ASTM A582, TYPE 303	ASTM A582, TYPE 303
9	NOZZLE SEAL	TEFLON, BUNA-N, VITON	TEFLON, BUNA-N, VITON	TEFLON, BUNA-N, VITON
10	BODY	ASTM A479, TYPE 316	ASTM B16	ASME SA29, TYPE 1018
11	SEAL & WIRE	LEAD SEAL/S/S WIRE	LEAD SEAL/COPPER WIRE	LEAD SEAL/COPPER WIRE
12	HOOD SEAL	TEFLON, BUNA-N, VITON	TEFLON, BUNA-N, VITON	TEFLON, BUNA-N, VITON