

SAFETY-RELIEF VALVE MODEL 4200 (SERIES 424 & 425)

FOR AIR & GAS SERVICE
AT 10% OVERPRESSURE
METAL SEATS ONLY

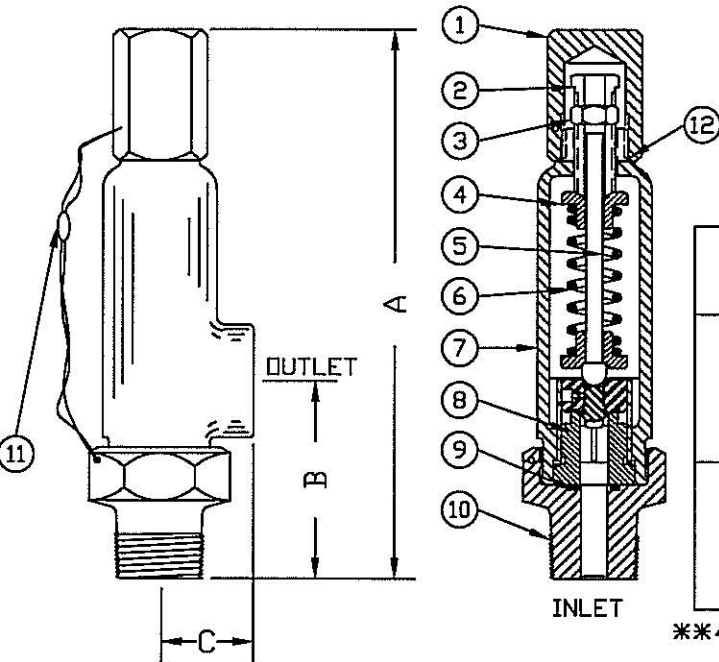

THREAD CONNECTIONS

ORIFICE SIZE	INLET	OUTLET
.375	1/2,3/4,1,1 1/4,1 1/2 MNPT	3/4,1,2 FNPT
	1/2,3/4,1,1 1/4,1 1/2 FNPT	MS33649-12,16
	MS33649-8,10,12,16	MS33656-12
.437	3/4,1,1 1/4,1 1/2,2 MNPT	1,2 FNPT
	3/4,1,1 1/4,1 1/2 FNPT	**MS33649-16 CANT HAVE CONE ON MS33656-16 ADAPTER
	MS33649-8,12,16	
	MS33656-12	

**425 RELIEF VALVE WITH MS33649-16 OUTLET
MUST USE MS33656-16 WITH NO CONE

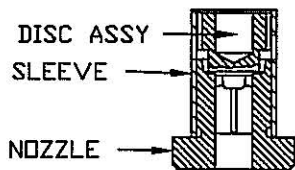

INNER VALVE UNIT DETAIL
METAL SEAT

SERIES NO. §	ORIFICE SIZE	SEAT MATERIAL	SET PRESSURE RANGE
424	.375	METAL ONLY	50 - 9,900
425	.437	METAL ONLY	50 - 3,650

DIMENSIONS	A ±1/8	B ±1/8	C ±1/16	APPROX WEIGHT
1 1/4, 1 1/2, 2' MNPT x 2' FNPT	9"	3-7/8	2-1/8	7#
ALL OTHERS	8-3/8	3"	1-7/16	4-1/2#

BACK PRESSURE SEALS AVAILABLE UPON REQUEST

I.V.U. FOR .437 C/S CLASS IS 17-4 PH;
303 S/S; 316 S/S.

† OTHER SPRING MATERIALS UPON REQUEST

§ SEE PAGE 91 & 92 FOR PART NUMBERING SYSTEM

ITEM NO.	PART NAME	316 S/S MATERIAL CLASS	BRONZE MATERIAL CLASS	CARBON STEEL MATERIAL CLASS
1	HOOD	ASTM A479,TYPE 316	ASTM B16	ASME SA29,TYPE 12L14
2	PRESSURE SCREW	ASTM A479,TYPE 316	ASTM A582,TYPE 303	ASTM A582,TYPE 303
3	LOCKNUT	ASTM A479,TYPE 316	ASTM A582,TYPE 303	ASTM A582,TYPE 303
4	SPRING PLATES (2)	ASTM A479,TYPE 316	ASTM A582,TYPE 303	ASTM A582,TYPE 303
5	SPRING POST	ASTM A479,TYPE 316	ASTM A582,TYPE 303	ASTM A582,TYPE 303
6	SPRING †	ASTM A313,TYPE 316	ASTM A313,TYPE 316	ASTM A313,TYPE 316
7	BONNET	ASME A351,TYPE CF8M	ASTM B584,ALLOY 875	ASTM A395
8	INNER VALVE UNIT	ASTM A479,TYPE 316	ASTM A582,TYPE 303	ASTM A582,TYPE 303
9	NOZZLE SEAL	TEFLON,BUNA-N,VITON	TEFLON,BUNA-N,VITON	TEFLON,BUNA-N,VITON
10	BODY	ASTM A479,TYPE 316	ASTM B16	ASME SA29,TYPE 1018
11	SEAL & WIRE	LEAD SEAL/S/S WIRE	LEAD SEAL/COPPER WIRE	LEAD SEAL/COPPER WIRE
12	HOOD SEAL	TEFLON,BUNA-N,VITON	TEFLON,BUNA-N,VITON	TEFLON,BUNA-N,VITON