

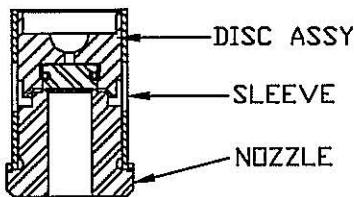

SAFETY-RELIEF VALVE MODEL 4900 (SERIES 494 & 496)

FOR AIR & GAS SERVICE
AT 10% OVERPRESSURE
METAL SEATS ONLY

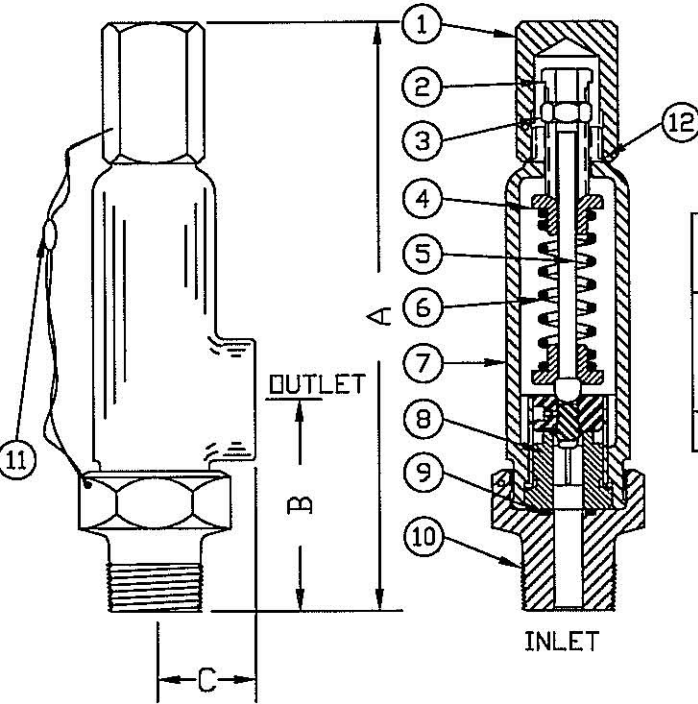

INNER VALVE UNIT DETAIL
METAL SEAT

THREAD CONNECTIONS

ORIFICE SIZE	INLET	OUTLET
.375	3/4, 1, 1 1/4, 1 1/2, 2 MNPT	1/2, 3/4, 1, 2" FNPT
	1/2, 3/4, 1 FNPT	**MS33649-16 CAN'T HAVE CONE ON MS33656-16 ADAPTER
.500	1 1/4, 1 1/2, 2 MNPT	2 FNPT

**494 RELIEF VALVE WITH MS33649-16 OUTLET
MUST USE MS33656-16 WITH NO CONE

SERIES NO. §	ORIFICE SIZE	SEAT MATERIAL	SET PRESSURE RANGE
494	.375	METAL ONLY	50 - 1,000
496	.500	METAL ONLY	50 - 1,000

DIMENSIONS	A ±1/8	B ±1/8	C ±1/16	APPROX WEIGHT
1 1/4, 1 1/2, 2" MNPT x 2" FNPT	9"	3-7/8	2-1/8	7#
ALL OTHERS	8-3/8	3"	1-7/16	4-1/2#

‡ OTHER SPRING MATERIALS UPON REQUEST
§ SEE PAGE 91 & 92 FOR PART NUMBERING SYSTEM
BACK PRESSURE SEALS AVAILABLE UPON REQUEST

ITEM NO.	PART NAME	316 S/S MATERIAL CLASS	BRONZE MATERIAL CLASS	CARBON STEEL MATERIAL CLASS
1	HOOD	ASTM A479, TYPE 316	ASTM B16	ASME SA29, TYPE 12L14
2	PRESSURE SCREW	ASTM A479, TYPE 316	ASME A582, TYPE 303	ASME A582, TYPE 303
3	LOCKNUT	ASTM A479, TYPE 316	ASME A582, TYPE 303	ASME A582, TYPE 303
4	SPRING PLATES (2)	ASTM A479, TYPE 316	ASME A582, TYPE 303	ASME A582, TYPE 303
5	SPRING POST	ASTM A479, TYPE 316	ASME A582, TYPE 303	ASME A582, TYPE 303
6	SPRING †	ASTM A313, TYPE 316	ASTM A313, TYPE 316	ASTM A313, TYPE 316
7	BONNET	ASME A351, TYPE CF8M	ASTM B584, ALLLOY 875	ASTM A395
8	INNER VALVE UNIT	ASTM A479, TYPE 316	ASME A582, TYPE 303	ASME A582, TYPE 303
9	NOZZLE SEAL	TEFLON, BUNA-N, METAL	TEFLON, BUNA-N, METAL	TEFLON, BUNA-N, METAL
10	BODY	ASTM A479, TYPE 316	ASTM B16	ASME SA29, TYPE 1018
11	SEAL & WIRE	LEAD SEAL/S/S WIRE	LEAD SEAL/COPPER WIRE	LEAD SEAL/COPPER WIRE
12	HOOD SEAL	TEFLON, BUNA-N, VITON	TEFLON, BUNA-N, VITON	TEFLON, BUNA-N, VITON