

SAFETY-RELIEF VALVE MODEL A4400

(SERIES A441, A442, A443, A445 & A446)

FOR AIR AND GAS SERVICE
AT 10% OVERPRESSURE

SEE PAGE 60 FOR LIFTING DEVICES.

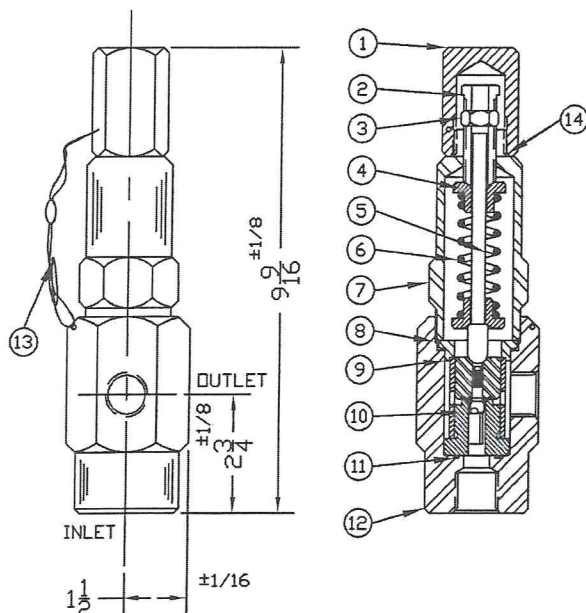

THREAD CONNECTIONS

ORIFICE SIZE	INLET	OUTLET
.187 & .250	3/8, 1/2, 3/4 FNPT	1/2, 3/4 FNPT
	1/4, 9/16 AMINCO	MS33649-4, 6, 8
.312 & .437	1/2, 3/4 FNPT	1/2, 3/4 FNPT
	1/4, 9/16 AMINCO	MS33649-8
.500	3/4 FNPT	3/4 FNPT
	MS33649-12	

SEE PAGE 53 & 54 FOR CAPACITY CHARTS.

SERIES NO. §	ORIFICE SIZE	SEAT MATERIAL	SET PRESSURE RANGE
A441	.187	PLASTIC ONLY	50 - 33,000
A442	.250	PLASTIC ONLY	50 - 16,000
A443	.312	PLASTIC ONLY	50 - 12,000
A445	.437	PLASTIC ONLY	50 - 7,300
A446	.500	PLASTIC ONLY	50 - 4,900

§ SEE PAGE 91 & 92 FOR PART NUMBERING SYSTEM.

SUGGESTED SEAT MATERIAL

SET PRESSURE	SEAT MATERIAL
50 - 3,000	TEFLON †
3,000 - 5,000	KEL-F †
5,000 - 33,000	VESPEL †

INNER VALVE UNIT DETAIL

WEIGHT IS APPROX. 11#
† OTHER SPRING MATERIALS UPON REQUEST.

‡ TEMPERATURE RANGE: TEFLON : -450°F TO 500°F
KEL-F : -400°F TO 400°F
VESPEL : -420°F TO 500°F

ITEM NO.	PART NAME	303 S/S MATERIAL CLASS	316 S/S MATERIAL CLASS
1	HOOD	ASTM A582, TYPE 303	ASTM A479, TYPE 316
2	PRESSURE SCREW	ASTM A582, TYPE 303	ASTM A479, TYPE 316
3	LOCKNUT	ASTM A582, TYPE 303	ASTM A479, TYPE 316
4	SPRING PLATES (2)	ASTM A582, TYPE 303	ASTM A479, TYPE 316
5	SPRING POST	ASTM A582, TYPE 303	ASTM A479, TYPE 316
6	SPRING	ASTM A313, TYPE 316	ASTM A313, TYPE 316
7	BONNET	ASTM A582, TYPE 303	ASTM A479, TYPE 316
8	BODY SEAL	TEFLON, BUNA-N, VITON	TEFLON, BUNA-N, VITON
9	RETAINER RING	ASTM A582, TYPE 303	ASTM A479, TYPE 316
10	INNER VALVE UNIT	ASTM A582, TYPE 303	ASTM A479, TYPE 316
11	NOZZLE SEAL	TEFLON, BUNA-N, VITON	TEFLON, BUNA-N, VITON
12	BODY	ASTM A582, TYPE 303	ASTM A479, TYPE 316
13	SEAL & WIRE	LEAD SEAL/S WIRE	LEAD SEAL/S WIRE
14	HOOD SEAL	TEFLON, BUNA-N, VITON	TEFLON, BUNA-N, VITON