



# SAFETY-RELIEF VALVE

## MODEL 1700

(SERIES 1713 & 1719)

\*\*THESE DIMENSIONS ARE GOOD FOR  
1" FNPT & MS33649-16 ALSO.

FOR LIQUID SERVICE  
AT 10% OVERPRESSURE

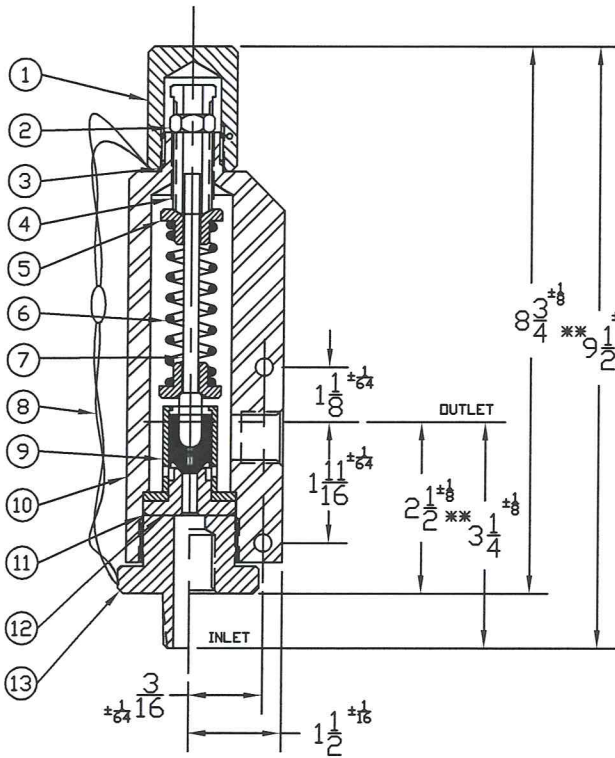

### THREAD CONNECTIONS

ORIFICE SIZE	INLET	OUTLET
.187	1/4, 3/8, 1/2, 3/4, 1" FNPT	1/2, 3/4, 1" FNPT
	1/4, 3/8, 1/2, 3/4, 1" MNPT	MS33649-4, 6, 8, 12, 16
	MS33649-4, 6, 8, 10, 12, 16	
	MS33656-8, 10, 12, 16	
	1/4, 3/8, 9/16, 3/4, 1" AUTOCLAVE	
.375	1/4, 9/16 HP AMINCO GRAYLOC	GRAYLOC
	3/4, 1" FNPT AUTOCLAVE	1" FNPT AUTOCLAVE
	3/4, 1" MNPT	MS33649-16
	MS33649-12, 16	
	MS33656-12, 16	

SEE PAGE 72 & 73 FOR CAPACITY CHART  
§ SEE PAGE 89 & 90 FOR PART NUMBERING SYSTEM.

SERIES NO. §	ORIFICE SIZE	SEAT MATERIAL	SET PRESSURE RANGE
1719	.187	PLASTIC ONLY	40 - 15,000
1713	.375	PLASTIC ONLY	40 - 3,500

### SUGGESTED SEAT MATERIAL

SET PRESSURE	SEAT MATERIAL
40 - 3,000	TEFLON †
3,000 - 3,500	KEL-F †

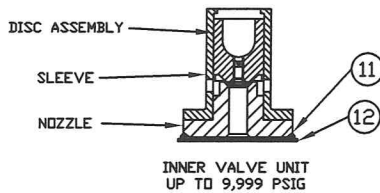

† TEMPERATURE RANGE  
TEFLON : -450°F TO 500°F  
KEL-F : -400°F TO 400°F

† OTHER SPRING MATERIALS  
AVAILABLE UPON REQUEST.

\*\*\*IVU FOR .375  
C/S OR 316 S/S CLASS HAS  
303 S/S SLEEVE  
316 S/S NOZZLE

WEIGHT IS APPROX. 9#

ITEM NO.	PART NAME	316 S/S MATERIAL CLASS	CARBON STEEL MATERIAL CLASS
1	HOOD	ASTM A479, TYPE 316	ASME SA29, TYPE 12L14
2	LOCKNUT	ASTM A479, TYPE 316	ASTM A582, TYPE 303
3	HOOD SEAL	TEFLON, BUNA-N, VITON	TEFLON, BUNA-N, VITON
4	PRESSURE SCREW	ASTM A479, TYPE 316	ASTM A582, TYPE 303
5	SPRING PLATES	ASTM A479, TYPE 316	ASTM A582, TYPE 303
6	SPRING	ASTM A313, TYPE 17/7	ASTM A313, TYPE 17/7
7	SPRING POST	ASTM A479, TYPE 316	ASTM A582, TYPE 303
8	SEAL & WIRE	LEAD SEAL, S/S WIRE	LEAD SEAL, S/S WIRE
9	INNER VALVE UNIT***	ASTM A479, TYPE 316	ASTM A479, TYPE 316
10	BONNET	ASTM A479, TYPE 316	ASME SA29, TYPE 1018
11	BODY SEAL	TEFLON, BUNA-N, VITON	TEFLON, BUNA-N, VITON
12	GASKET	TEFLON	TEFLON
13	BODY	ASTM A479, TYPE 316	ASME SA29, TYPE 1018