

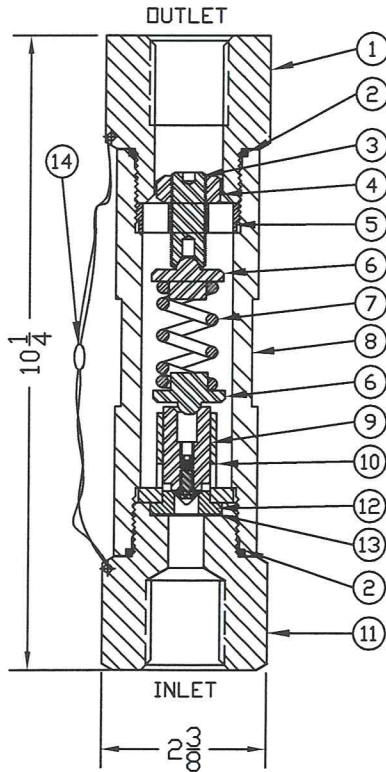

# INLINE SAFETY-RELIEF VALVE MODEL 5200 (SERIES 527)

FOR GAS AND AIR SERVICE



### THREAD CONNECTIONS

ORIFICE SIZE	INLET	OUTLET
.625	1,1¼,1½" FNPT	1,1¼,1½" FNPT
	1,1¼,1½" MNPT	1,1¼,1½" MNPT
	MS33649-16,20,24	MS33649-16,20,24
	MS33656-16,24	MS33656-16,24

SERIES NO. §	ORIFICE SIZE	SEAT MATERIAL	SET PRESSURE RANGE	BURST PRESSURE
527	.625	PLASTIC ONLY	1 - 3,000	12,000

### SUGGESTED SEAT MATERIAL

SET PRESSURE	SEAT MATERIAL
1 - 75	*O-RING DESIGN *
50 - 3,000	TEFLON †

† TEMPERATURE RANGE: TEFLON : -450°F TO 500°F

WEIGHT APPROXIMATELY 9-1/2#

† OTHER SPRING MATERIALS UPON REQUEST

§ SEE PAGE 91 & 92 FOR PART NUMBERING SYSTEM

\* SEATS DESIGNED WITH BUNA-N, VITON, EPR OR KALREZ ARE AVAILABLE FOR CLOSE RESEAT APPLICATIONS.

ITEM NO.	PART NAME	316 S/S MATERIAL CLASS	BRONZE MATERIAL CLASS	303 S/S MATERIAL CLASS
1	BONNET	ASTM A479,TYPE 316	ASTM B16	ASTM A582,TYPE 303
2	*O* RING	TEFLON,BUNA-N,VITON	TEFLON,BUNA-N,VITON	TEFLON,BUNA-N,VITON
3	PRESSURE SCREW	ASTM A479,TYPE 316	ASTM A582,TYPE 303	ASTM A582,TYPE 303
4	LOCKNUT	ASTM A479,TYPE 316	ASTM A582,TYPE 303	ASTM A582,TYPE 303
5	SPRING RETAINER	ASTM A479,TYPE 316	ASTM A582,TYPE 303	ASTM A582,TYPE 303
6	SPRING PLATES (2)	ASTM A479,TYPE 316	ASTM A582,TYPE 303	ASTM A582,TYPE 303
7	SPRING †	ASTM A313,TYPE 316	ASTM A313,TYPE 316	ASTM A313,TYPE 316
8	BODY	ASTM A479,TYPE 316	ASTM B16	ASTM A582,TYPE 303
9	DISC ASSEMBLY	ASTM A479,TYPE 316	ASTM A582,TYPE 303	ASTM A582,TYPE 303
10	DISC GUIDE	ASTM A479,TYPE 316	ASTM A582,TYPE 303	ASTM A582,TYPE 303
11	BASE	ASTM A479,TYPE 316	ASTM B16	ASTM A582,TYPE 303
12	NOZZLE	ASTM A479,TYPE 316	ASTM A582,TYPE 303	ASTM A582,TYPE 303
13	GASKET	TEFLON	TEFLON	TEFLON
14	SEAL & WIRE	LEAD SEAL:S/S WIRE	LEAD SEAL: COPPER WIRE	LEAD SEAL:S/S WIRE